

# INTENSIF ASAS

TAHUN 6

# MATEMATIK

BAB	TOPIK
1.	Nombor Bulat hingga 10 000
2.	Tambah dalam Lingkungan 10 000
3.	Tolak dalam Lingkungan 10 000
4.	Darab
5.	Bahagi
6.	Pecahan
7.	Perpuluhan
8.	Peratus
9.	Wang
10.	Masa dan Waktu
11.	Panjang
12.	Jisim
13.	Isipadu Cecair
14.	Ruang
15.	Perwakilan Data

*Professional Maths Centre™*

**MATHS CATCH**

**Dwibahasa**

LEBIH DARI **328 SOALAN** TERPILIH BERTARAF PEPERIKSAAN DAN BERKUALITI TINGGI DAN SANGAT SESUAI UNTUK KEGUNAAN PELAJAR TAHUN 3 SEBAGAI LATIHAN ASAS SEMPENA CUTI SEKOLAH

# Anda Ibu Bapa Atau Guru?



## DAPATKAN SEKARANG

- 1 Lebih 50 Live Video **CARA BANTU ANAK** Kuasai Matematik
- 2 Lebih **30 EBOOK SOALAN** Latihan Matematik Tahun 1 – Tingkatan 5
- 3 Koleksi Soalan Peperiksaan **PERCUBAAN** yang lepas-lepas
- 4 Percuma Soalan Peperiksaan **AKHIR TAHUN** Edisi Khas
- 5 **CADANGAN TAJUK** dan Soalan Pilihan menjelang peperiksaan
- 6 **'CASE STUDY'** bagaimana saya bantu ribuan pelajar saya melonjak dari **E NAIK KE A** dan lain-lain
- 7 Lebih dari **30 KAJIAN KES PETUA & STRATEGI** menguasai matematik yang dilakukan oleh MathsCatch Team

Bagi yang belum mendaftar emel. Cadangan saya daftar segera. Kerana lebih banyak info akan saya kirimkan melalui emel. Daftar Percuma disini

[kingpagi.com](http://kingpagi.com)

*“Semoga membantu anak-anak anda”*



**CG RAJAEI**

**LATIHAN CUTI SEKOLAH:**

**UNIT 1: NOMBOR & OPERASI**

**ASAS 1**

1.  $6\,579 - 6\,578 + 9\,010 =$
2.  $672\,879 + 242\,773 - 611\,273 =$
3.  $402 \times 1\,000 \div 8 =$
4.  $46\,869 \div 51 \times 14 =$
5.  $775 - 4\,150 \div 10 =$
6.  $94\,200 + 104 \times 57 =$
7.  $(133 - 51) \times 100 =$
8.  $7\,200 \div (3 + 9) =$
9.  $(20 - 5) \times (683 + 317) =$
10.  $(860 - 499) \times (16 + 21) =$

11. Round the numbers to the nearest ten.

3 486 837	
-----------	--

12. Round the numbers to the nearest ten.

8 432 187	
-----------	--

13. Round the numbers to the nearest hundred thousand.

9 950 445	
-----------	--

14. Round the numbers to the nearest million.

7 969 654	
-----------	--

15. Round the number to the nearest place values shown.

Number	Tens	Hundreds	Thousands	Ten thousands	Hundred thousands	Millions
891 840						

16. Round the number to the nearest place values shown.

Number	Tens	Hundreds	Thousands	Ten thousands	Hundred thousands	Millions
2 067 418						

17. What is the biggest number that can be formed with the following digits?

6, 4, 3, 1, 2, 7, 8	
---------------------	--

18. What is the smallest number that can be formed with the following digits?

1, 8, 5, 6, 4, 2, 7	
---------------------	--

19. What is the sum of the digit value of 5 and the digit value of 9 in the following number?

6 489 325	
-----------	--

20. What is the sum of the digit value of 3 and the digit value of 5 in the following number?

9 138 765	
-----------	--

21. What is the difference of the digit value of 4 in card A and the digit value of 5 in card B?

Card A
1 435 768

Card B
5 819 647

Answer: \_\_\_\_\_

22. What is the difference of the digit value of 3 in card A and the digit value of 1 in card B?

Card A
2 317 485

Card B
8 921 645

Answer: \_\_\_\_\_

23. Among the following numbers, the digit value of 3 in which number is the biggest?

7 950 613

7 264 093

4 605 931

5 721 863

24. Among the following numbers, the digit value of 6 in which number is the biggest?

1 038 456

9 813 764

1 582 346

5 397 406

25. Which of the following numbers, when rounded to the nearest million will become 6 000 000?

6 149 420

5 100 921

5 193 206

6 967 419

26. Which of the following numbers, when rounded to the nearest million will become 7 000 000?

7 065 257

7 954 432

7 986 243

6 373 655

27. Correct the decimal number to 2 decimal places.

9.329

28. Correct the decimal number to 1 decimal places.

3.092

29. Use calculator to solve the following.  
589 489 ÷ 52 (2 decimal places)

30. Use calculator to solve the following.  
662 211 ÷ 94 (3 decimal places)

31. Complete the number sequence.

	324	326		330	
--	-----	-----	--	-----	--

32. Complete the number sequence.

			415	420	425
--	--	--	-----	-----	-----

33. Complete the number sequence.

5	11	18	26		
---	----	----	----	--	--

34. Complete the number sequence.

764	766	769	773		
-----	-----	-----	-----	--	--

35. Complete the number sequence.

2	4	8	16		
---	---	---	----	--	--

36. Complete the number sequence.

4	16	64	256		
---	----	----	-----	--	--

37.

Number	Question	Yes / No
7	Can be divided by 1?	
	Can be divided by itself?	
	Can be divided by other numbers?	
	7 is a prime number?	

38.

Number	Question	Yes / No
29	Can be divided by 1?	
	Can be divided by itself?	
	Can be divided by other numbers?	
	29 is a prime number?	

39. Circle the prime numbers.

2      15

40. Circle the prime numbers.

17      25      3      21      5      27

41. Write the prime number after 19.

42. Write the prime number after 37.

43. Write the number.

Eight million	
---------------	--

44. Write the number.

Nine million five hundred sixty thousand fifty-seven	
--	--

45. Write the number in words.

8000000	
---------	--

46. Write the number in words.

8230070	
---------	--

47. Write the place value for the underlined digit.

4 350 <u>9</u> 40	
-------------------	--

48. Write the place value for the underlined digit.

4 138 <u>8</u> 16	
-------------------	--

49. Which digit has the place value ten thousands? Circle it.

9	6	1	2	4	8	7
---	---	---	---	---	---	---

50. Which digit has the place value millions? Circle it.

3	9	3	7	9	8	7
---	---	---	---	---	---	---

51. Write the digit value for the underlined digit.

7 0 <u>4</u> 1 556	
--------------------	--

52. Write the digit value for the underlined digit.

<u>2</u> 098 460	
------------------	--

53. Partition the number.

$$3\ 912\ 246 = \boxed{\phantom{000000}} + \boxed{\phantom{000000}} + \boxed{\phantom{000000}} + \boxed{\phantom{000000}} +$$

$$\boxed{\phantom{000000}} + \boxed{\phantom{000000}} + \boxed{\phantom{000000}}$$

54. Partition the number.

$$6\ 539\ 423 = \boxed{\phantom{000000}} + \boxed{\phantom{000000}} + \boxed{\phantom{000000}} + \boxed{\phantom{000000}} +$$

$$\boxed{\phantom{000000}} + \boxed{\phantom{000000}} + \boxed{\phantom{000000}}$$

55. Partition the number.

$$393\ 733 = \underline{\hspace{2cm}} \text{ hundred thousands} + \underline{\hspace{2cm}} \text{ ten thousands} + \underline{\hspace{2cm}} \text{ thousands}$$

$$+ \underline{\hspace{2cm}} \text{ hundreds} + \underline{\hspace{2cm}} \text{ tens} + \underline{\hspace{2cm}} \text{ ones}$$

56. Partition the number.

$$815\ 034 = \underline{\hspace{2cm}} \text{ hundred thousands} + \underline{\hspace{2cm}} \text{ ten thousand} + \underline{\hspace{2cm}} \text{ thousands} +$$

$$\underline{\hspace{2cm}} \text{ hundred} + \underline{\hspace{2cm}} \text{ tens} + \underline{\hspace{2cm}} \text{ ones}$$

57. Write the decimal in whole number.

$$1.6 \text{ million} =$$

58. Write the decimal in whole number.

$$2.88 \text{ million} =$$

59. Write the whole number in decimal.

$$3\ 700\ 000 = \underline{\hspace{2cm}} \text{ million}$$

60. Write the whole number in decimal.

$$5\ 250\ 000 = \underline{\hspace{2cm}} \text{ million}$$

61. Write the whole number in fraction.

$$2\,300\,000 = \underline{\hspace{2cm}} \text{ million}$$

62. Write the whole number in fraction.

$$8\,720\,000 = \underline{\hspace{2cm}} \text{ million}$$

63. Write the fraction in whole number.

$$8\frac{7}{10} \text{ million} =$$

64. Write the fraction in whole number.

$$9\frac{50}{100} \text{ million} =$$

65.  $3\,700\,000 - 0.2 \text{ million} = \underline{\hspace{2cm}} \text{ million}$

66.  $7.492 \text{ million} - 1\,037\,000 = \underline{\hspace{2cm}} \text{ million}$

67.  $2 \text{ million} + 0.043 \text{ million} \times 9 =$   
(Write the answer in whole number)

68.  $5.28 \text{ million} \div 5 - 0.124 \text{ million} =$   
(Write the answer in whole number)

69. Joseph has 3 117 red marbles. His father gives him an additional 46 packs of marbles, with each pack containing 10 green marbles. How many marbles does Joseph have in total now?
70. Lucy bought 78 bouquets of flower, with each bouquet containing 31 flowers. Later in the day, she bought another 6 817 flowers. What is the total number of flowers she bought?
71. There are 19 boxes of pens in a bookshop.
- Each box contains 80 blue pens and 20 black pens. How many rulers are there in a box?
  - How many pens are there in the bookshop?
72. A factory produces 240 red pens and 37 blue pens every day.
- How many pens produced by the factory every day?
  - What is the number of pens produced by the factory in 18 days?

73. The following table shows the number of fruits in a shopping complex.

Type	Number of Fruits
Watermelons	190
Apples	690 more than total number of watermelons and oranges
Oranges	150

Calculate the total number of fruits in the shopping complex.

74. The following table shows the number of books in a bookshop.

Type	Number of Books
Children books	669
Dictionaries	760 less than total number of children books and reference books
Reference books	589

Calculate the total number of books in the bookshop.

75. Company A and Company B donate 258 new books and 542 new books respectively to a library.
- (a) How many books have been donated?
- (b) There are 22 racks in the library. 12 of the racks were full even before the new books arrive, and the rest are empty. The new books are kept evenly on the empty racks. How many new books are there on each rack?
76. A distributor packs 76 red pens and 63 blue pens in a box.
- (a) How many pens are there in a box?
- (b) The distributor delivers similar boxes, 23 boxes to Shop A and 8 boxes to Shop B. How many pens have been delivered by the distributor?
77. A factory produces 9 million pens.  $3\frac{1}{2}$  million of the pens are stored in 100 boxes evenly.
- (a) How many pens are there in a box?
- (b) If a box of pens is sold, how many pens are left unsold? Write the answer in whole number.

78. Nizar gets 6.66 million points in a video game. His points is 3 times the points of Saravana.
- (a) How many points does Saravana get?
- (b) Jayden points is 2 million less than Saravana. Calculate the points of Jayden. Write the answer in whole number.

**ASAS 2**

INPUT		OUTPUT	
<b>1</b>	Which of the following numbers when rounded off to the nearest hundred thousand is 3 700 000? <i>Antara yang berikut, yang manakah apabila dibundarkan kepada ratus ribu yang terdekat ialah 3 700 000?</i> A 3 686 854      C 3 763 510 B 3 772 618      D 3 605 318	<b>1</b>	Which of the following numbers when rounded off to the nearest hundred thousand is 9 700 000? <i>Antara yang berikut, yang manakah apabila dibundarkan kepada ratus ribu yang terdekat ialah 9 700 000?</i> A 9 627 696      C 9 798 537 B 9 748 851      D 9 790 852
<b>2</b>	Which of the following represents $6\frac{3}{4}$ million? <i>Antara yang berikut, yang manakah mewakili <math>6\frac{3}{4}</math> juta?</i> A 6 000 507      C 6 700 050 B 6 000 705      D 6 750 000	<b>2</b>	Which of the following represents $7\frac{1}{4}$ million? <i>Antara yang berikut, yang manakah mewakili <math>7\frac{1}{4}</math> juta?</i> A 7 002 005      C 7 200 050 B 7 050 020      D 7 250 000
<b>3</b>	Which of the following sequences is arranged in descending order? <i>Antara yang berikut, yang manakah disusun dalam urutan menurun?</i> A 8 132 978, 8 173 928, 8 129 738, 8 123 798 B 8 760 423, 8 702 463, 8 706 243, 8 724 063 C 2 538 290, 2 583 290, 2 589 230, 2 532 890 D 9 963 750, 9 697 350, 9 695 370, 9 673 950	<b>3</b>	Which of the following sequences is arranged in descending order? <i>Antara yang berikut, yang manakah disusun dalam urutan menurun?</i> A 5 059 327, 5 532 907, 5 390 257, 5 592 307 B 7 540 271, 7 527 041, 7 527 401, 7 520 471 C 3 983 145, 3 981 345, 3 931 485, 3 913 485 D 1 384 079, 1 340 789, 1 347 809, 1 348 079

<p>4 Which of the following numbers when rounded off to the nearest hundred thousand is not 6 900 000? <i>Antara yang berikut, yang manakah apablia dibundarkan kepada ratus ribu yang terdekat bukan 6 900 000?</i></p> <p>A 6 976 246      C 6 943 204 B 6 920 040      D 6 948 661</p>	<p>4 Which of the following numbers when rounded off to the nearest hundred thousand is not 5 000 000? <i>Antara yang berikut, yang manakah apablia dibundarkan kepada ratus ribu yang terdekat bukan 5 000 000?</i></p> <p>A 5 040 300      C 5 038 498 B 5 000 126      D 4 933 117</p>
<p>5 Round off 630 410 to the nearest hundred thousand. <i>630 410 dibundarkan kepada ratus ribu yang terdekat ialah</i></p> <p>A 0.59 million      C 0.50 million <i>0.59 juta              0.50 juta</i> B 0.60 million      D 0.61 million <i>0.60 juta              0.61 juta</i></p>	<p>5 Round off 3 627 412 to the nearest million. <i>3 627 412 dibundarkan kepada juta yang terdekat ialah</i></p> <p>A 4.1 million      C 4.0 million <i>4.1 juta              4.0 juta</i> B 3.0 million      D 3.9 million <i>3.0 juta              3.9 juta</i></p>
<p>6 Which of the following represents <math>9\frac{3}{4}</math> million? <i>Antara yang berikut, yang manakah mewakili <math>9\frac{3}{4}</math> juta?</i></p> <p>A 9 050 007      C 9 500 700 B 9 050 700      D 9 750 000</p>	<p>6 Which of the following represents <math>7\frac{1}{4}</math> million? <i>Antara yang berikut, yang manakah mewakili <math>7\frac{1}{4}</math> juta?</i></p> <p>A 7 000 520      C 7 250 000 B 7 200 005      D 7 500 020</p>
<p>7 Which of the following numbers has the smallest value? <i>Antara yang berikut, yang manakah mempunyai nilai yang terkecil?</i></p> <p>A 4 463 948      C 4 469 348 B 4 464 398      D 4 469 438</p>	<p>7 Which of the following numbers has the smallest value? <i>Antara yang berikut, yang manakah mempunyai nilai yang terkecil?</i></p> <p>A 3 309 143      C 3 304 913 B 3 301 493      D 3 301 943</p>
<p>8 Diagram 1 a number sequence. <i>Rajah 1 menunjukkan satu urutan nombor.</i></p> <div style="border: 1px solid black; padding: 5px; width: fit-content; margin: 10px auto;"> <p>463 685, M, 463 865, 463 955</p> </div> <p style="text-align: center;"><b>Diagram 1</b> <b>Rajah 1</b></p> <p>What is the value of M? <i>Apakah nilai M?</i></p> <p>A 463 775      C 463 505 B 463 784      D 463 595</p>	<p>8 Diagram 1 a number sequence. <i>Rajah 1 menunjukkan satu urutan nombor.</i></p> <div style="border: 1px solid black; padding: 5px; width: fit-content; margin: 10px auto;"> <p>M, 253 243, 253 743, 254 243</p> </div> <p style="text-align: center;"><b>Diagram 1</b> <b>Rajah 1</b></p> <p>What is the value of M? <i>Apakah nilai M?</i></p> <p>A 252 243      C 251 743 B 252 793      D 252 743</p>
<p>9 Which of the following represents <math>8\frac{3}{4}</math> million? <i>Antara yang berikut, yang manakah mewakili <math>8\frac{3}{4}</math> juta?</i></p> <p>A 8 000 057      C 8 500 700 B 8 070 050      D 8 750 000</p>	<p>9 Which of the following represents <math>8\frac{5}{8}</math> million? <i>Antara yang berikut, yang manakah mewakili <math>8\frac{5}{8}</math> juta?</i></p> <p>A 8 002 056      C 8 600 520 B 8 025 600      D 8 625 000</p>

**10** Diagram 2 shows two number cards.  
*Rajah 2 menunjukkan dua keping kad nombor.*

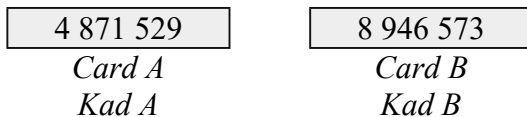

**Diagram 2**  
**Rajah 2**

What is the difference between the values of digits 8 in Card A and 4 in Card B?

*Berapakah perbezaan nilai digit 8 di Kad A dan 4 di Kad B?*

- A 799 600      C 760 000  
B 796 000      D 40 000

**10** Diagram 2 shows two number cards.  
*Rajah 2 menunjukkan dua keping kad nombor.*

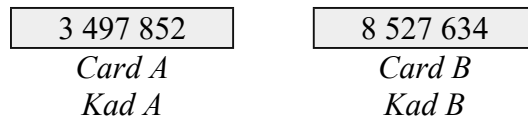

**Diagram 2**  
**Rajah 2**

What is the difference between the values of digits 3 in Card A and 2 in Card B?

*Berapakah perbezaan nilai digit 3 di Kad A dan 2 di Kad B?*

- A 2 999 800      C 2 980 000  
B 2 998 000      D 280 000

**11** Diagram 3 shows a number line.  
*Rajah 3 menunjukkan satu garis nombor.*

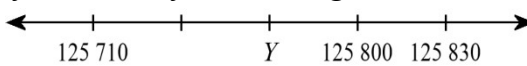

**Diagram 3**  
**Rajah 3**

What is the value of Y?

*Apakah nilai Y?*

- A 125 650      C 125 770  
B 125 773      D 125 680

**11** Diagram 3 shows a number line.  
*Rajah 3 menunjukkan satu garis nombor.*

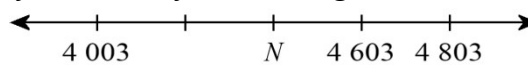

**Diagram 3**  
**Rajah 3**

What is the value of N?

*Apakah nilai N?*

- A 3 603      C 4 403  
B 4 423      D 3 803

**12** Which of the following numbers has the biggest value?

*Antara yang berikut, yang manakah mempunyai nilai yang terbesar?*

- A 4 887 418      C 4 881 478  
B 4 881 748      D 4 884 178

**12** Which of the following numbers has the biggest value?

*Antara yang berikut, yang manakah mempunyai nilai yang terbesar?*

- A 2 938 529      C 2 932 589  
B 2 932 859      D 2 935 289

**13** Afandi gets 2 265 225 points from a contest. His points are 762 048 more than Han Ling's points. Azizi's points are 510 746 less than Han Ling. How many points does Azizi have?

*Afandi mendapat 2 265 225 poin dalam satu pertandingan. Poin dia adalah 762 048 lebih banyak berbanding dengan Han Ling.*

*Poin Azizi adalah 510 746 kurang berbanding dengan Han Ling. Berapakah poin yang Azizi ada?*

- A 992 431      C 993 431  
B 1 002 431      D 991 431

**13** Alif gets 6 874 431 points from a contest. His points are 3 508 045 more than Gomez's points. Chee Hong's points are 1 098 920 less than Gomez. How many points does Chee Hong have?

*Alif mendapat 6 874 431 poin dalam satu pertandingan. Poin dia adalah 3 508 045 lebih banyak berbanding dengan Gomez.*

*Poin Chee Hong adalah 1 098 920 kurang berbanding dengan Gomez. Berapakah poin yang Chee Hong ada?*

- A 2 277 466      C 2 268 466  
B 2 267 466      D 2 266 466

**14** Diagram 4 shows the number of balls in two containers.  
*Rajah 4 menunjukkan jumlah bola yang terdapat dalam dua bekas.*

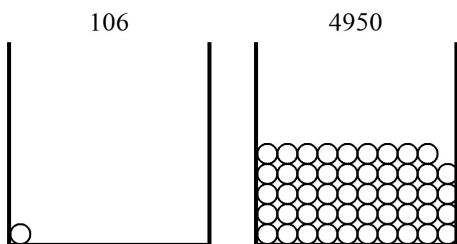

**Diagram 4**  
**Rajah 4**

What is the total number of balls if 203 balls are added to each container?

*Berapakah jumlah bola yang terdapat dalam kedua-dua bekas itu jika 203 bola ditambah ke dalam setiap bekas?*

- A 5 056                      C 5 259  
B 4 853                      D 5 462

**15** Which of the following has the largest value?

*Antara yang berikut, yang manakah mempunyai nilai yang terbesar?*

- A  $10\,000 \times 2$               C  $20 \times 1\,000$   
B  $2 \times 100\,000$             D  $100 \times 2$

**16**  $83\,978 + 404\,388 + 35\,825 + 4\,455\,417 =$   
A 4 979 608              C 4 989 608  
B 4 978 608              D 4 980 608

**17** Raidah buys a set of comics with a total of 8 970 pages. She read 5 437 pages on the first day and 1 410 pages on the second day. How many pages were left for Raidah to read?

*Raidah membeli satu set komik dengan jumlah 8 970 muka surat. Raidah membaca 5 437 muka surat pada hari pertama dan 1 410 muka surat pada hari kedua. Berapakah muka surat yang tinggal untuk dibaca oleh Raidah?*

- A 12 123                      C 2 123  
B 1 123                        D 3 123

**14** Diagram 4 shows the number of balls in two containers.  
*Rajah 4 menunjukkan jumlah bola yang terdapat dalam dua bekas.*

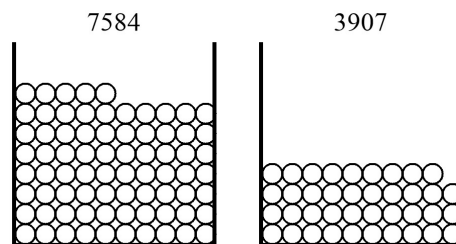

**Diagram 4**  
**Rajah 4**

What is the total number of balls if 713 balls are added to each container?

*Berapakah jumlah bola yang terdapat dalam kedua-dua bekas itu jika 713 bola ditambah ke dalam setiap bekas?*

- A 11 491                      C 12 917  
B 10 778                      D 12 204

**15** Which of the following has the largest value?

*Antara yang berikut, yang manakah mempunyai nilai yang terbesar?*

- A  $650 \times 1\,000$               C  $65 \times 100\,000$   
B  $100 \times 65$                 D  $10\,000 \times 65$

**16**  $604\,724 + 2\,017\,337 + 342\,212 + 4\,211\,600 =$   
A 7 176 873              C 7 174 873  
B 7 185 873              D 7 175 873

**17** Husna buys a set of comics with a total of 2 576 pages. She read 871 pages on the first day and 1 044 pages on the second day. How many pages were left for Husna to read?

*Husna membeli satu set komik dengan jumlah 2 576 muka surat. Husna membaca 871 muka surat pada hari pertama dan 1 044 muka surat pada hari kedua. Berapakah muka surat yang tinggal untuk dibaca oleh Husna?*

- A 661                         C 10 661  
B 1 661                      D 330

<p><b>18</b> Phaik Hoon buys a set of comics with a total of 6 720 pages. She read 5 075 pages on the first day and 1 346 pages on the second day. How many pages were left for Phaik Hoon to read? <i>Phaik Hoon membeli satu set komik dengan jumlah 6 720 muka surat. Phaik Hoon membaca 5 075 muka surat pada hari pertama dan 1 346 muka surat pada hari kedua. Berapakah muka surat yang tinggal untuk dibaca oleh Phaik Hoon?</i></p> <p>A 1 299                      C 299 B 149                          D 10 299</p>	<p><b>18</b> Urmah buys a set of comics with a total of 6 189 pages. She read 331 pages on the first day and 3 777 pages on the second day. How many pages were left for Urmah to read? <i>Urmah membeli satu set komik dengan jumlah 6 189 muka surat. Urmah membaca 331 muka surat pada hari pertama dan 3 777 muka surat pada hari kedua. Berapakah muka surat yang tinggal untuk dibaca oleh Urmah?</i></p> <p>A 1 081                      C 3 081 B 2 081                      D 12 081</p>
<p><b>19</b> A factory manufactures 40 104 toys in 18 days. How many toys does the factory manufacture in one day? <i>Sebuah kilang menghasilkan 40 104 mainan dalam masa 18 hari. Berapakah bilangan mainan yang dihasilkan dalam satu hari?</i></p> <p>A 2 228                      C 2 264 B 2 210                      D 2 246</p>	<p><b>19</b> A factory manufactures 51 350 toys in 13 days. How many toys does the factory manufacture in one day? <i>Sebuah kilang menghasilkan 51 350 mainan dalam masa 13 hari. Berapakah bilangan mainan yang dihasilkan dalam satu hari?</i></p> <p>A 3 963                      C 3 976 B 3 950                      D 3 937</p>
<p><b>20</b> Ghazali Store buys 442 348 packs of sweets last year. Each pack consists of 20 sweets. What is the total number of sweets bought by Ghazali Store last year? <i>Kedai Ghazali membeli 442 348 pek gula-gula pada tahun lepas. Setiap pek mengandungi 20 gula-gula. Berapakah jumlah gula-gula yang dibeli oleh Kedai Ghazali pada tahun lepas?</i></p> <p>A 8 847 960                C 8 845 960 B 8 846 960                D 884 696</p>	<p><b>20</b> Bakri Store buys 83 476 packs of sweets last year. Each pack consists of 65 sweets. What is the total number of sweets bought by Bakri Store last year? <i>Kedai Bakri membeli 83 476 pek gula-gula pada tahun lepas. Setiap pek mengandungi 65 gula-gula. Berapakah jumlah gula-gula yang dibeli oleh Kedai Bakri pada tahun lepas?</i></p> <p>A 5 424 940                C 5 425 940 B 5 426 940                D 542 594</p>
<p><b>21</b> Given that <math>237\,730 \div 60 = 3\,962</math> remainder 10. Which of the following number is divisible by 60? <i>Diberi <math>237\,730 \div 60 = 3\,962</math> baki 10. Antara yang berikut, yang manakah dapat dibahagi dengan 60?</i></p> <p>A 237 720                      C 237 725 B 237 715                      D 237 723</p>	<p><b>21</b> Given that <math>6\,354\,713 \div 56 = 113\,477</math> remainder 1. Which of the following number is divisible by 56? <i>Diberi <math>6\,354\,713 \div 56 = 113\,477</math> baki 1. Antara yang berikut, yang manakah dapat dibahagi dengan 56?</i></p> <p>A 6 354 718                C 6 354 707 B 6 354 713                D 6 354 712</p>
<p><b>22</b> <math>3\,767\,576 \div 52 = \square</math> What is the remainder of the division above? <i>Berapakah baki pembahagian di atas?</i></p> <p>A 20                              C 22 B 200                            D 21</p>	<p><b>22</b> <math>9\,776\,540 \div 7 = \square</math> What is the remainder of the division above? <i>Berapakah baki pembahagian di atas?</i></p> <p>A 40                              C 4 B 6                                D 5</p>
<p><b>23</b> <math>\square - 2\,481\,249 - 2\,060\,017 = 401\,831</math></p> <p>A 4 942 097                C 4 943 097 B 4 944 097                D 4 953 097</p>	<p><b>23</b> <math>\square - 4\,622\,282 - 626\,817 = 2\,736\,751</math></p> <p>A 7 985 850                C 7 984 850 B 7 986 850                D 7 995 850</p>

<p><b>24</b> <math>1\ 281\ 240 - \square - 50\ 361 = 165\ 486</math>  <b>A</b> 1 075 393      <b>C</b> 1 066 393  <b>B</b> 1 065 393      <b>D</b> 1 064 393</p>	<p><b>24</b> <math>321\ 367 - \square - 152\ 776 = 114\ 031</math>  <b>A</b> 64 560              <b>C</b> 53 560  <b>B</b> 55 560              <b>D</b> 54 560</p>
<p><b>25</b> <math>2\ 539\ 894 - 1.53\ \text{million} =</math>  <math>2\ 539\ 894 - 1.53\ \text{juta} =</math>                      Round off the answer to the nearest hundred thousand.  <i>Bundarkan jawapan kepada ratus ribu yang terdekat.</i>  <b>A</b> 1.01 million      <b>C</b> 0.90 million  <i>1.01 juta              0.90 juta</i>  <b>B</b> 1.00 million      <b>D</b> 0.99 million  <i>1.00 juta              0.99 juta</i></p>	<p><b>25</b> <math>5\ 007\ 328 - 3.45\ \text{million} =</math>  <math>5\ 007\ 328 - 3.45\ \text{juta} =</math>                      Round off the answer to the nearest hundred thousand.  <i>Bundarkan jawapan kepada ratus ribu yang terdekat.</i>  <b>A</b> 1.60 million      <b>C</b> 1.61 million  <i>1.60 juta              1.61 juta</i>  <b>B</b> 1.59 million      <b>D</b> 1.50 million  <i>1.59 juta              1.50 juta</i></p>
<p><b>26</b> All the following are equal, except  <i>Semua di bawah adalah sama kecuali</i>  <b>A</b> <math>10 \times 922\ 199</math>      <b>C</b> <math>34 \times 271\ 245</math>  <b>B</b> <math>85 \times 108\ 494</math>      <b>D</b> <math>17 \times 542\ 470</math></p>	<p><b>26</b> All the following are equal, except  <i>Semua di bawah adalah sama kecuali</i>  <b>A</b> <math>11 \times 469\ 266</math>      <b>C</b> <math>22 \times 234\ 628</math>  <b>B</b> <math>44 \times 117\ 314</math>      <b>D</b> <math>88 \times 58\ 657</math></p>
<p><b>27</b> Given that <math>6\ 744\ 156 \div 45 = 149\ 870</math> remainder 6. Which of the following number is divisible by 45?  <i>Diberi <math>6\ 744\ 156 \div 45 = 149\ 870</math> baki 6. Antara yang berikut, yang manakah dapat dibahagi dengan 45?</i>  <b>A</b> 6 744 153      <b>C</b> 6 744 146  <b>B</b> 6 744 156      <b>D</b> 6 744 150</p>	<p><b>27</b> Given that <math>1\ 629\ 336 \div 48 = 33\ 944</math> remainder 24. Which of the following number is divisible by 48?  <i>Diberi <math>1\ 629\ 336 \div 48 = 33\ 944</math> baki 24. Antara yang berikut, yang manakah dapat dibahagi dengan 48?</i>  <b>A</b> 1 629 313      <b>C</b> 1 629 312  <b>B</b> 1 629 308      <b>D</b> 1 629 324</p>
<p><b>28</b> Maziah buys a set of comics with a total of 1 208 pages. She read 257 pages on the first day and 718 pages on the second day. How many pages were left for Maziah to read?  <i>Maziah membeli satu set komik dengan jumlah 1 208 muka surat. Maziah membaca 257 muka surat pada hari pertama dan 718 muka surat pada hari kedua. Berapakah muka surat yang tinggal untuk dibaca oleh Maziah?</i>  <b>A</b> 1 233              <b>C</b> 233  <b>B</b> 10 233              <b>D</b> 116</p>	<p><b>28</b> Abidah buys a set of comics with a total of 7 739 pages. She read 2 268 pages on the first day and 1 289 pages on the second day. How many pages were left for Abidah to read?  <i>Abidah membeli satu set komik dengan jumlah 7 739 muka surat. Abidah membaca 2 268 muka surat pada hari pertama dan 1 289 muka surat pada hari kedua. Berapakah muka surat yang tinggal untuk dibaca oleh Abidah?</i>  <b>A</b> 5 182              <b>C</b> 4 182  <b>B</b> 14 182              <b>D</b> 3 182</p>
<p><b>29</b> <math>5\ 320\ 776 \div \square = 47</math>  <b>A</b> 113 210              <b>C</b> 113 208  <b>B</b> 226 416              <b>D</b> 113 209</p>	<p><b>29</b> <math>9\ 593\ 296 \div \square = 8</math>  <b>A</b> 2 398 324              <b>C</b> 1 199 163  <b>B</b> 1 199 164              <b>D</b> 1 199 162</p>
<p><b>30</b> <math>1\ 338\ 466 - 138\ 423 - \square = 37\ 906</math>  <b>A</b> 1 163 137              <b>C</b> 1 162 137  <b>B</b> 1 161 137              <b>D</b> 1 172 137</p>	<p><b>30</b> <math>6\ 653\ 142 - 2\ 248\ 176 - \square = 3\ 189\ 710</math>  <b>A</b> 1 216 256              <b>C</b> 1 215 256  <b>B</b> 1 225 256              <b>D</b> 1 214 256</p>
<p><b>31</b> What is the product of 47 081 and 38?  <i>Berapakah hasil darab 47 081 dan 38?</i>  <b>A</b> 1 790 078              <b>C</b> 1 789 078  <b>B</b> 1 788 078              <b>D</b> 178 907</p>	<p><b>31</b> What is the product of 21 182 and 40?  <i>Berapakah hasil darab 21 182 dan 40?</i>  <b>A</b> 848 280              <b>C</b> 847 280  <b>B</b> 846 280              <b>D</b> 84 728</p>

<p><b>32</b> Khairuddin gets 4 779 959 points from a contest. His points are 2 623 523 more than Rasyid's points. Hamid's points are 1 203 983 less than Rasyid. How many points does Hamid have? <i>Khairuddin mendapat 4 779 959 poin dalam satu pertandingan. Poin dia adalah 2 623 523 lebih banyak berbanding dengan Rasyid. Poin Hamid adalah 1 203 983 kurang berbanding dengan Rasyid. Berapakah poin yang Hamid ada?</i></p> <p>A 962 453                      C 952 453 B 951 453                      D 953 453</p>	<p><b>32</b> Ridhwan gets 5 551 964 points from a contest. His points are 1 169 900 more than Nagapan's points. Akif's points are 4 103 766 less than Nagapan. How many points does Akif have? <i>Ridhwan mendapat 5 551 964 poin dalam satu pertandingan. Poin dia adalah 1 169 900 lebih banyak berbanding dengan Nagapan. Poin Akif adalah 4 103 766 kurang berbanding dengan Nagapan. Berapakah poin yang Akif ada?</i></p> <p>A 277 298                      C 278 298 B 279 298                      D 288 298</p>
<p><b>33</b> <math>1\,209\,639 - 452\,864 - 368\,072 =</math></p> <p>A 389 703                      C 398 703 B 387 703                      D 388 703</p>	<p><b>33</b> <math>7\,033\,980 - 2\,627\,330 - 217\,493 =</math></p> <p>A 4 189 157                      C 4 188 157 B 4 190 157                      D 4 199 157</p>
<p><b>34</b> What must be subtracted from 3 772 746 to get 1 860 501? <i>Apakah nombor yang perlu ditolak daripada 3 772 746 untuk mendapat 1 860 501?</i></p> <p>A 1 912 245                      C 1 913 245 B 1 911 245                      D 1 922 245</p>	<p><b>34</b> What must be subtracted from 8 907 829 to get 97 619? <i>Apakah nombor yang perlu ditolak daripada 8 907 829 untuk mendapat 97 619?</i></p> <p>A 8 810 210                      C 8 811 210 B 8 820 210                      D 8 809 210</p>
<p><b>35</b> What must be added to 2 103 548 so that the total is 2 860 000? <i>Apakah nombor yang perlu ditambah kepada 2 103 548 untuk mendapat 2 860 000?</i></p> <p>A 756 452                      C 766 452 B 757 452                      D 755 452</p>	<p><b>35</b> What must be added to 4 114 668 so that the total is 8 990 000? <i>Apakah nombor yang perlu ditambah kepada 4 114 668 untuk mendapat 8 990 000?</i></p> <p>A 4 885 332                      C 4 875 332 B 4 874 332                      D 4 876 332</p>
<p><b>36</b> <math>2\,341\,048 - 1\,708\,550 + 2\,238\,805 =</math></p> <p>A 2 871 403                      C 2 871 293 B 2 871 503                      D 2 871 303</p>	<p><b>36</b> <math>3\,937\,813 - 2\,770\,098 + 4\,761\,337 =</math></p> <p>A 5 929 052                      C 5 929 042 B 5 929 252                      D 5 929 152</p>
<p><b>37</b> <math>(980 \times 19) - (106 \times 18) =</math></p> <p>A 1 908                          C 20 528 B 16 712                          D 123 876</p>	<p><b>37</b> <math>(847 \times 19) - (672 \times 5) =</math></p> <p>A 12 733                          C 14 077 B 13 405                          D 16 093</p>
<p><b>38</b> <math>1\,160\,764 + 1\,165\,970 - 2\,288\,415 =</math></p> <p>A 38 319                          C 38 419 B 38 309                          D 38 519</p>	<p><b>38</b> <math>1\,001\,844 + 1\,296\,192 - 1\,858\,106 =</math></p> <p>A 439 930                          C 439 920 B 440 130                          D 440 030</p>
<p><b>39</b> <math>87\,939 \div (56 - 29) =</math></p> <p>A 3 257                          C 7 352 B 5 237                          D 7 523</p>	<p><b>39</b> <math>80\,604 \div (23 - 11) =</math></p> <p>A 1 677                          C 6 717 B 1 767                          D 7 716</p>

**40** Table 1 shows the number of students in a college last year.  
*Jadual 1 menunjukkan bilangan pelajar di sebuah kolej tahun lepas.*

Sex <i>Jantina</i>	Male <i>Lelaki</i>	Female <i>Perempuan</i>
Number of students <i>Bilangan pelajar</i>	99 253	57 611

**Table 1**  
**Jadual 1**

46 444 students left the college in the beginning of the year. What is the number of students who remain in the college?  
*46 444 tinggalkan kolej itu pada awal tahun ini. Berapakah bilangan pelajar yang masih belajar di kolej itu?*

- A** 110 420                      **C** 110 410  
**B** 110 620                      **D** 110 520

**40** Table 1 shows the number of students in a college last year.  
*Jadual 1 menunjukkan bilangan pelajar di sebuah kolej tahun lepas.*

Sex <i>Jantina</i>	Male <i>Lelaki</i>	Female <i>Perempuan</i>
Number of students <i>Bilangan pelajar</i>	2 513 166	2 446 362

**Table 1**  
**Jadual 1**

4 407 561 students left the college in the beginning of the year. What is the number of students who remain in the college?  
*4 407 561 tinggalkan kolej itu pada awal tahun ini. Berapakah bilangan pelajar yang masih belajar di kolej itu?*

- A** 551 967                      **C** 552 067  
**B** 551 957                      **D** 552 167

**LATIHAN CUTI SEKOLAH:**  
**UNIT 2: PECAHAN**

**ASAS 1**

- $\frac{8}{9} \times \frac{2}{7} =$
- $4\frac{4}{9} \times 2\frac{1}{4} =$
- $\frac{2}{3} \times \frac{1}{4} =$
- $7\frac{1}{2} \times 2\frac{1}{2} =$
- $\frac{2}{3} \times \frac{1}{5} =$
- $6\frac{2}{7} \times 2 =$
- $\frac{2}{3} \times \square = \frac{4}{21}$
- $\square \times 7\frac{1}{10} = 31\frac{19}{20}$
- $\frac{2}{7} \div 2 =$
- $\frac{3}{7} \div 4 =$

11.  $6\frac{1}{8} \div 7 =$

12.  $5\frac{6}{7} \div 4 =$

13.  $\frac{1}{4} \div \frac{1}{2} =$

14.  $\frac{3}{10} \div \frac{5}{6} =$

15.  $6\frac{1}{7} \div \frac{1}{2} =$

16.  $9\frac{5}{6} \div \frac{2}{9} =$

17.  $3\frac{1}{9} \times \square = 15\frac{5}{9}$

18.  $8\frac{1}{4} \times \square = 12\frac{3}{8}$

19. If a factory takes  $4\frac{4}{5}$  hours to assemble a car, how many hours would it take to assemble 15 cars?

20. There are  $9\frac{6}{7}$  packs of rice in a store. The average mass of a pack of rice is 511 kg. What is the total kg of rice in the store?

21. The following table shows the number of books in a book fair.

Type	Number of Books
Children books	400
Comics	1000
Novels	$\frac{1}{7}$ of the total number of children books and comics

Calculate the total number of books in the book fair.

22. The following table shows the number of people in a shopping complex.

People	Number of People
Girls	5 900
Boys	$\frac{3}{4}$ of the total number of girls and adults
Adults	9 200

Calculate the total number of people in the shopping complex.

**ASAS 2**

INPUT		OUTPUT	
<b>1</b>	$4\frac{1}{7} + 5\frac{3}{7} + 4\frac{1}{7} =$ A $11\frac{5}{7}$ C $13\frac{5}{7}$ B $12\frac{5}{7}$ D $14\frac{5}{7}$	<b>1</b>	$4\frac{6}{7} + 2\frac{5}{7} + 2\frac{5}{7} =$ A $8\frac{2}{7}$ C $10\frac{2}{7}$ B $9\frac{2}{7}$ D $11\frac{2}{7}$
<b>2</b>	Syahidah bought $6\frac{1}{3}$ m of green ribbon, $1\frac{1}{2}$ m of red ribbon and $3\frac{1}{3}$ m of white ribbon to wrap a hamper. Find the length of ribbon that she used. <i>Syahidah membeli <math>6\frac{1}{3}</math> m reben green, <math>1\frac{1}{2}</math> m reben red, dan <math>3\frac{1}{3}</math> m reben white untuk menghiasi satu bakul. Berapakah panjang reben yang telah digunakan oleh Syahidah?</i> A $11\frac{1}{6}$ m                      C $13\frac{1}{6}$ m B $12\frac{1}{6}$ m                      D $14\frac{1}{6}$ m	<b>2</b>	Ghanimah bought $3\frac{5}{8}$ m of blue ribbon, $7\frac{7}{8}$ m of black ribbon and $1\frac{1}{2}$ m of white ribbon to wrap a hamper. Find the length of ribbon that she used. <i>Ghanimah membeli <math>3\frac{5}{8}</math> m reben blue, <math>7\frac{7}{8}</math> m reben black, dan <math>1\frac{1}{2}</math> m reben white untuk menghiasi satu bakul. Berapakah panjang reben yang telah digunakan oleh Ghanimah?</i> A 13 m                      C 15 m B 14 m                      D 16 m
<b>3</b>	$3\frac{1}{7} + 5\frac{4}{5} + 1\frac{1}{5} =$ A $10\frac{1}{7}$ C $12\frac{1}{7}$ B $11\frac{1}{7}$ D $13\frac{1}{7}$	<b>3</b>	$8\frac{2}{3} + 1\frac{7}{10} + 2\frac{1}{3} =$ A $9\frac{7}{10}$ C $11\frac{7}{10}$ B $10\frac{7}{10}$ D $12\frac{7}{10}$

<p>4 Zaimah bought <math>4\frac{2}{5}</math> m of red ribbon, <math>4\frac{1}{2}</math> m of black ribbon and <math>3\frac{1}{2}</math> m of purple ribbon to wrap a hamper. Find the length of ribbon that she used.</p> <p><i>Zaimah membeli <math>4\frac{2}{5}</math> m reben red, <math>4\frac{1}{2}</math> m reben black, dan <math>3\frac{1}{2}</math> m reben purple untuk menghiasi satu bakul. Berapakah panjang reben yang telah digunakan oleh Zaimah?</i></p> <p>A <math>10\frac{2}{5}</math> m                      C <math>12\frac{2}{5}</math> m B <math>11\frac{2}{5}</math> m                      D <math>13\frac{2}{5}</math> m</p>	<p>4 Chai Ling bought <math>2\frac{4}{9}</math> m of brown ribbon, <math>6\frac{8}{9}</math> m of white ribbon and <math>3\frac{1}{2}</math> m of red ribbon to wrap a hamper. Find the length of ribbon that she used.</p> <p><i>Chai Ling membeli <math>2\frac{4}{9}</math> m reben brown, <math>6\frac{8}{9}</math> m reben white, dan <math>3\frac{1}{2}</math> m reben red untuk menghiasi satu bakul. Berapakah panjang reben yang telah digunakan oleh Chai Ling?</i></p> <p>A <math>12\frac{5}{6}</math> m                      C <math>14\frac{5}{6}</math> m B <math>13\frac{5}{6}</math> m                      D <math>15\frac{5}{6}</math> m</p>
<p>5 Sufi used sand and cement to repair his house. He used <math>3\frac{7}{9}</math> kg of sand. The cement he used is <math>3\frac{1}{3}</math> kg more than the sand he used. What is the total mass of sand and cement that he used?</p> <p><i>Sufi menggunakan pasir dan simen untuk membaiki rumahnya. Dia menggunakan <math>3\frac{7}{9}</math> kg pasir. Simen yang digunakannya adalah <math>3\frac{1}{3}</math> kg lebih daripada pasir yang digunakan. Apakah jumlah jisim pasir dan simen yang telah digunakan?</i></p> <p>A <math>7\frac{8}{9}</math> kg                      C <math>9\frac{8}{9}</math> kg B <math>8\frac{8}{9}</math> kg                      D <math>10\frac{8}{9}</math> kg</p>	<p>5 Amir used sand and cement to repair his house. He used <math>2\frac{1}{2}</math> kg of sand. The cement he used is <math>2\frac{3}{4}</math> kg more than the sand he used. What is the total mass of sand and cement that he used?</p> <p><i>Amir menggunakan pasir dan simen untuk membaiki rumahnya. Dia menggunakan <math>2\frac{1}{2}</math> kg pasir. Simen yang digunakannya adalah <math>2\frac{3}{4}</math> kg lebih daripada pasir yang digunakan. Apakah jumlah jisim pasir dan simen yang telah digunakan?</i></p> <p>A <math>5\frac{3}{4}</math> kg                      C <math>7\frac{3}{4}</math> kg B <math>6\frac{3}{4}</math> kg                      D <math>8\frac{3}{4}</math> kg</p>
<p>6 <math>7\frac{1}{2} + 1\frac{1}{2} + 3\frac{1}{2} =</math></p> <p>A <math>10\frac{1}{2}</math>                      C <math>12\frac{1}{2}</math> B <math>11\frac{1}{2}</math>                      D <math>13\frac{1}{2}</math></p>	<p>6 <math>2\frac{1}{3} + 6\frac{1}{3} + 1\frac{1}{3} =</math></p> <p>A 7                              C 9 B 8                              D 10</p>
<p>7 The sum of <math>1\frac{2}{3}</math>, <math>8\frac{1}{9}</math> and <math>2\frac{5}{9}</math> is</p> <p><i>Hasil tambah <math>1\frac{2}{3}</math>, <math>8\frac{1}{9}</math>, dan <math>2\frac{5}{9}</math> ialah</i></p> <p>A <math>10\frac{1}{3}</math>                      C <math>12\frac{1}{3}</math> B <math>11\frac{1}{3}</math>                      D <math>13\frac{1}{3}</math></p>	<p>7 The sum of <math>4\frac{1}{4}</math>, <math>4\frac{3}{4}</math> and <math>2\frac{1}{3}</math> is</p> <p><i>Hasil tambah <math>4\frac{1}{4}</math>, <math>4\frac{3}{4}</math>, dan <math>2\frac{1}{3}</math> ialah</i></p> <p>A <math>8\frac{1}{3}</math>                              C <math>10\frac{1}{3}</math> B <math>9\frac{1}{3}</math>                              D <math>11\frac{1}{3}</math></p>

8 Which of the following is the nearest to 10?  
*Antara yang berikut, jumlah yang manakah paling hampir dengan 10?*

- A  $10\frac{1}{5} + \frac{1}{10}$       C  $10\frac{3}{5} + \frac{1}{5}$   
B  $10\frac{3}{4} + \frac{1}{2}$       D  $9\frac{1}{3} + \frac{1}{6}$

8 Which of the following is the nearest to 3?  
*Antara yang berikut, jumlah yang manakah paling hampir dengan 3?*

- A  $2\frac{3}{4} + \frac{1}{2}$       C  $2\frac{4}{5} + \frac{3}{5}$   
B  $3\frac{1}{4} + \frac{1}{2}$       D  $3\frac{5}{8} + \frac{3}{4}$

9 Diagram 1 shows a number line.  
*Rajah 1 menunjukkan satu garis nombor.*

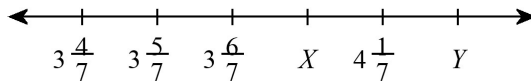

**Diagram 1**  
**Rajah 1**

What is the value of  $3\frac{5}{7} + X + Y$ ?

*Apakah nilai  $3\frac{5}{7} + X + Y$ ?*

- A 11      C 13  
B 12      D 14

9 Diagram 1 shows a number line.  
*Rajah 1 menunjukkan satu garis nombor.*

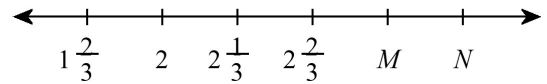

**Diagram 1**  
**Rajah 1**

What is the value of  $3\frac{1}{9} + M + N$ ?

*Apakah nilai  $3\frac{1}{9} + M + N$ ?*

- A  $7\frac{4}{9}$       C  $9\frac{4}{9}$   
B  $8\frac{4}{9}$       D  $10\frac{4}{9}$

10 Table 1 shows the masses of three fruits.  
*Jadual 1 menunjukkan jisim tiga buah-buahan.*

Fruit <i>Buah-buahan</i>	Durian <i>Durian</i>	Papaya <i>Betik</i>	Water melon <i>Tembikai</i>
Mass (kg) <i>Jisim (kg)</i>	$1\frac{1}{2}$	$2\frac{1}{2}$	$2\frac{1}{2}$

What is the total mass of the three fruits?  
*Apakah jumlah jisim ketiga-tiga buah-buahan itu?*

- A  $5\frac{1}{2}$  kg      C  $7\frac{1}{2}$  kg  
B  $6\frac{1}{2}$  kg      D  $8\frac{1}{2}$  kg

10 Table 1 shows the masses of three fruits.  
*Jadual 1 menunjukkan jisim tiga buah-buahan.*

Fruit <i>Buah-buahan</i>	Durian <i>Durian</i>	Papaya <i>Betik</i>	Water melon <i>Tembikai</i>
Mass (kg) <i>Jisim (kg)</i>	$1\frac{7}{9}$	$1\frac{8}{9}$	$2\frac{1}{6}$

What is the total mass of the three fruits?  
*Apakah jumlah jisim ketiga-tiga buah-buahan itu?*

- A  $2\frac{5}{6}$  kg      C  $4\frac{5}{6}$  kg  
B  $3\frac{5}{6}$  kg      D  $5\frac{5}{6}$  kg

11 Atiyah spent  $4\frac{4}{5}$  hours to complete his mathematics homework. He spent  $3\frac{1}{5}$  hours longer to complete his science homework. What is the total time he spent to complete his homework?

Atiyah menggunakan  $4\frac{4}{5}$  jam untuk menyiapkan kerja rumah matematik. Dia menggunakan  $3\frac{1}{5}$  jam lebih lama untuk menyiapkan kerja rumah sains. Berapa lamakah masa yang digunakan oleh Atiyah untuk menyiapkan kerja rumahnya?

- A  $10\frac{4}{5}$                       C  $12\frac{4}{5}$   
B  $11\frac{4}{5}$                       D  $13\frac{4}{5}$

11 Asri spent  $1\frac{1}{2}$  hours to complete his mathematics homework. He spent  $3\frac{7}{10}$  hours longer to complete his science homework. What is the total time he spent to complete his homework?

Asri menggunakan  $1\frac{1}{2}$  jam untuk menyiapkan kerja rumah matematik. Dia menggunakan  $3\frac{7}{10}$  jam lebih lama untuk menyiapkan kerja rumah sains. Berapa lamakah masa yang digunakan oleh Asri untuk menyiapkan kerja rumahnya?

- A  $4\frac{7}{10}$                       C  $6\frac{7}{10}$   
B  $5\frac{7}{10}$                       D  $7\frac{7}{10}$

12 Diagram 2 shows a number line. Rajah 2 menunjukkan satu garis nombor.

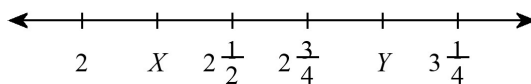

**Diagram 2**  
**Rajah 2**

What is the value of  $6\frac{3}{4} - X - Y$ ?

Apakah nilai  $6\frac{3}{4} - X - Y$ ?

- A  $\frac{1}{2}$                       C  $2\frac{1}{2}$   
B  $1\frac{1}{2}$                       D  $3\frac{1}{2}$

12 Diagram 2 shows a number line. Rajah 2 menunjukkan satu garis nombor.

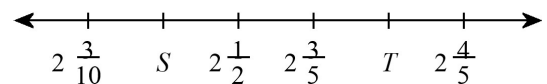

**Diagram 2**  
**Rajah 2**

What is the value of  $7\frac{2}{5} - S - T$ ?

Apakah nilai  $7\frac{2}{5} - S - T$ ?

- A  $1\frac{3}{10}$                       C  $3\frac{3}{10}$   
B  $2\frac{3}{10}$                       D  $4\frac{3}{10}$

13 Diagram 3 shows a number line. Rajah 3 menunjukkan satu garis nombor.

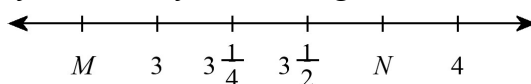

**Diagram 3**  
**Rajah 3**

What is the value of  $8\frac{1}{2} - M - N$ ?

Apakah nilai  $8\frac{1}{2} - M - N$ ?

- A 1                      C 3  
B 2                      D 4

13 Diagram 3 shows a number line. Rajah 3 menunjukkan satu garis nombor.

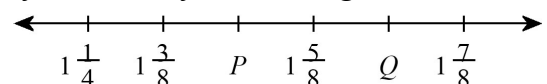

**Diagram 3**  
**Rajah 3**

What is the value of  $7\frac{1}{4} - P - Q$ ?

Apakah nilai  $7\frac{1}{4} - P - Q$ ?

- A 2                      C 4  
B 3                      D 5

14 Maryam had  $6\frac{1}{2}$  kg of flour. She made two cakes using  $2\frac{1}{2}$  kg of flour for each one. Find the mass of flour left.

*Maryam mempunyai  $6\frac{1}{2}$  kg tepung. Dia membuat dua kek dengan menggunakan  $2\frac{1}{2}$  kg tepung setiap satu. Berapakah jisim tepung yang masih ada?*

- A  $\frac{1}{2}$  kg                      C  $2\frac{1}{2}$  kg  
B  $1\frac{1}{2}$  kg                      D  $3\frac{1}{2}$  kg

14 Rasinah had  $3\frac{1}{3}$  kg of flour. She made two cakes using  $1\frac{1}{2}$  kg of flour for each one. Find the mass of flour left.

*Rasinah mempunyai  $3\frac{1}{3}$  kg tepung. Dia membuat dua kek dengan menggunakan  $1\frac{1}{2}$  kg tepung setiap satu. Berapakah jisim tepung yang masih ada?*

- A  $\frac{1}{3}$  kg                      C  $2\frac{1}{3}$  kg  
B  $1\frac{1}{3}$  kg                      D  $3\frac{1}{3}$  kg

15 Diagram 4 shows a number line. Rajah 4 menunjukkan satu garis nombor.

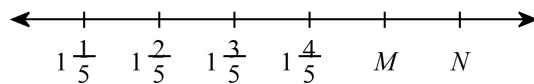

**Diagram 4**  
**Rajah 4**

What is the value of  $6\frac{7}{10} - M - N$ ?

*Apakah nilai  $6\frac{7}{10} - M - N$ ?*

- A  $2\frac{1}{2}$                       C  $4\frac{1}{2}$   
B  $3\frac{1}{2}$                       D  $5\frac{1}{2}$

15 Diagram 4 shows a number line. Rajah 4 menunjukkan satu garis nombor.

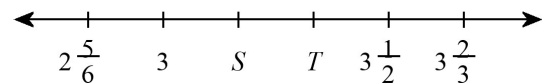

**Diagram 4**  
**Rajah 4**

What is the value of  $8\frac{7}{8} - S - T$ ?

*Apakah nilai  $8\frac{7}{8} - S - T$ ?*

- A  $\frac{3}{8}$                       C  $2\frac{3}{8}$   
B  $1\frac{3}{8}$                       D  $3\frac{3}{8}$

16  $6 - 4\frac{7}{10} + 2\frac{1}{2} =$

- A  $2\frac{4}{5}$                       C  $4\frac{4}{5}$   
B  $3\frac{4}{5}$                       D  $5\frac{4}{5}$

16  $9 - 1\frac{1}{2} + 1\frac{1}{8} =$

- A  $7\frac{5}{8}$                       C  $9\frac{5}{8}$   
B  $8\frac{5}{8}$                       D  $10\frac{5}{8}$

17 Idris bought  $5\frac{1}{2}$  m of cloth. He made two shirts using  $1\frac{3}{4}$  m and  $2\frac{1}{2}$  m of cloth for each one. What is the length of cloth left?

*Idris membeli  $5\frac{1}{2}$  m kain. Dia membuat dua baju dengan  $1\frac{3}{4}$  m dan  $2\frac{1}{2}$  m kain masing-masing. Berapa panjangkah kain yang tinggal?*

- A  $1\frac{1}{4}$  m                      C  $3\frac{1}{4}$  m  
B  $2\frac{1}{4}$  m                      D  $4\frac{1}{4}$  m

17 Amaluddin bought  $7\frac{2}{5}$  m of cloth. He made two shirts using  $3\frac{2}{5}$  m and  $2\frac{4}{5}$  m of cloth for each one. What is the length of cloth left?

*Amaluddin membeli  $7\frac{2}{5}$  m kain. Dia membuat dua baju dengan  $3\frac{2}{5}$  m dan  $2\frac{4}{5}$  m kain masing-masing. Berapa panjangkah kain yang tinggal?*

- A  $\frac{1}{5}$  m                      C  $2\frac{1}{5}$  m  
 $1\frac{1}{5}$  m                      D  $3\frac{1}{5}$  m

18 Diagram 5 shows a number line.  
*Rajah 5 menunjukkan satu garis nombor.*

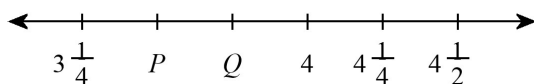

**Diagram 5**  
**Rajah 5**

What is the value of  $7\frac{1}{2} - P - Q$ ?

*Apakah nilai  $7\frac{1}{2} - P - Q$ ?*

- A  $\frac{1}{4}$                       C  $2\frac{1}{4}$   
B  $1\frac{1}{4}$                       D  $3\frac{1}{4}$

18 Diagram 5 shows a number line.  
*Rajah 5 menunjukkan satu garis nombor.*

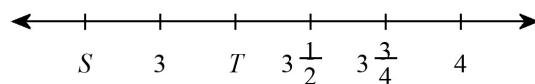

**Diagram 5**  
**Rajah 5**

What is the value of  $8\frac{1}{2} - S - T$ ?

*Apakah nilai  $8\frac{1}{2} - S - T$ ?*

- A  $\frac{1}{2}$                       C  $2\frac{1}{2}$   
B  $1\frac{1}{2}$                       D  $3\frac{1}{2}$

19  $9\frac{2}{7} - 1\frac{5}{7} - 1\frac{2}{7} =$

- A  $4\frac{2}{7}$                       C  $6\frac{2}{7}$   
B  $5\frac{2}{7}$                       D  $7\frac{2}{7}$

19  $5\frac{2}{5} - 1\frac{3}{5} - 1\frac{3}{5} =$

- A  $1\frac{1}{5}$                       C  $3\frac{1}{5}$   
B  $2\frac{1}{5}$                       D  $4\frac{1}{5}$

20 Bazilah had  $9\frac{2}{3}$  kg of flour. She made two cakes using  $1\frac{3}{4}$  kg of flour for each one. Find the mass of flour left.

*Bazilah mempunyai  $9\frac{2}{3}$  kg tepung. Dia membuat dua kek dengan menggunakan  $1\frac{3}{4}$  kg tepung setiap satu. Berapakah jisim tepung yang masih ada?*

- A  $4\frac{1}{6}$  kg                      C  $6\frac{1}{6}$  kg  
B  $5\frac{1}{6}$  kg                      D  $7\frac{1}{6}$  kg

20 Sin Yee had  $7\frac{1}{2}$  kg of flour. She made two cakes using  $1\frac{1}{8}$  kg of flour for each one. Find the mass of flour left.

*Sin Yee mempunyai  $7\frac{1}{2}$  kg tepung. Dia membuat dua kek dengan menggunakan  $1\frac{1}{8}$  kg tepung setiap satu. Berapakah jisim tepung yang masih ada?*

- A  $3\frac{1}{4}$  kg                      C  $5\frac{1}{4}$  kg  
B  $4\frac{1}{4}$  kg                      D  $6\frac{1}{4}$  kg

21 Fauzi prepared  $9\frac{1}{2}$  ℓ of juices for a party. The guests drunk  $3\frac{1}{2}$  ℓ of orange juice and  $1\frac{1}{2}$  ℓ of rose juice. What is the volume of juice left?

*Fauzi menyediakan jus-jus sebanyak  $9\frac{1}{2}$  ℓ untuk satu jamuan. Para tetamu telah minum  $3\frac{1}{2}$  ℓ jus oren dan  $1\frac{1}{2}$  ℓ jus ros. Berapakah isi padu jus yang tinggal?*

21 Khalil prepared  $9\frac{1}{2}$  ℓ of juices for a party. The guests drunk  $3\frac{4}{5}$  ℓ of orange juice and  $3\frac{1}{2}$  ℓ of rose juice. What is the volume of juice left?

*Khalil menyediakan jus-jus sebanyak  $9\frac{1}{2}$  ℓ untuk satu jamuan. Para tetamu telah minum  $3\frac{4}{5}$  ℓ jus oren dan  $3\frac{1}{2}$  ℓ jus ros. Berapakah isi padu jus yang tinggal?*

<p>A <math>3\frac{1}{2} \ell</math>                      C <math>5\frac{1}{2} \ell</math>                      B <math>4\frac{1}{2} \ell</math>                      D <math>6\frac{1}{2} \ell</math></p>	<p>A <math>1\frac{1}{5} \ell</math>                      C <math>3\frac{1}{5} \ell</math>                      B <math>2\frac{1}{5} \ell</math>                      D <math>4\frac{1}{5} \ell</math></p>
<p><b>22</b> Subtract <math>4\frac{1}{6}</math> and <math>1\frac{2}{3}</math> from <math>7\frac{1}{2}</math>.  <i>Tolakkan <math>4\frac{1}{6}</math> dan <math>1\frac{2}{3}</math> daripada <math>7\frac{1}{2}</math>.</i>                      A <math>\frac{2}{3}</math>                              C <math>2\frac{2}{3}</math>                      B <math>1\frac{2}{3}</math>                              D <math>3\frac{2}{3}</math></p>	<p><b>22</b> Subtract <math>2\frac{2}{3}</math> and <math>2\frac{1}{6}</math> from <math>7\frac{2}{3}</math>.  <i>Tolakkan <math>2\frac{2}{3}</math> dan <math>2\frac{1}{6}</math> daripada <math>7\frac{2}{3}</math>.</i>                      A <math>\frac{5}{6}</math>                              C <math>2\frac{5}{6}</math>                      B <math>1\frac{5}{6}</math>                              D <math>3\frac{5}{6}</math></p>
<p><b>23</b> Amar bought <math>9\frac{7}{10} \ell</math> of paint. He used <math>6\frac{1}{2} \ell</math> of paint for his bedroom and <math>1\frac{1}{2} \ell</math> of paint for his living room. What is the volume of paint left?  <i>Amar membeli <math>9\frac{7}{10} \ell</math> cat. Dia menggunakan <math>6\frac{1}{2} \ell</math> cat untuk bilik tidurnya dan <math>1\frac{1}{2} \ell</math> cat untuk ruang tetamunya. Berapakah isi padu cat yang tinggal?</i>                      A <math>\frac{7}{10} \ell</math>                              C <math>2\frac{7}{10} \ell</math>                      B <math>1\frac{7}{10} \ell</math>                              D <math>3\frac{7}{10} \ell</math></p>	<p><b>23</b> Amnan bought <math>7\frac{8}{9} \ell</math> of paint. He used <math>2\frac{2}{3} \ell</math> of paint for his bedroom and <math>1\frac{1}{3} \ell</math> of paint for his living room. What is the volume of paint left?  <i>Amnan membeli <math>7\frac{8}{9} \ell</math> cat. Dia menggunakan <math>2\frac{2}{3} \ell</math> cat untuk bilik tidurnya dan <math>1\frac{1}{3} \ell</math> cat untuk ruang tetamunya. Berapakah isi padu cat yang tinggal?</i>                      A <math>2\frac{8}{9} \ell</math>                              C <math>4\frac{8}{9} \ell</math>                      B <math>3\frac{8}{9} \ell</math>                              D <math>5\frac{8}{9} \ell</math></p>
<p><b>24</b> <math>2\frac{2}{5} \times 870 =</math>                      A 2 088                              C 2 262                      B 2 175                              D 2 349</p>	<p><b>24</b> <math>7\frac{7}{9} \times 954 =</math>                      A 7 102                              C 7 314                      B 7 208                              D 7 420</p>
<p><b>25</b> <math>6\frac{3}{4} \times 136 =</math>                      A 850                                  C 918                      B 884                                  D 952</p>	<p><b>25</b> <math>2\frac{1}{2} \times 980 =</math>                      A 2 450                              C 2 646                      B 2 548                              D 2 744</p>
<p><b>26</b> The product of <math>8\frac{3}{7}</math> and 588 is  <i>Hasil darab <math>8\frac{3}{7}</math> dan 588 ialah</i>                      A 4 956                              C 5 124                      B 5 040                              D 5 208</p>	<p><b>26</b> The product of <math>7\frac{1}{2}</math> and 602 is  <i>Hasil darab <math>7\frac{1}{2}</math> dan 602 ialah</i>                      A 4 063                              C 4 364                      B 4 214                              D 4 515</p>
<p><b>27</b> <math>\frac{1}{3}</math> of 156 is  <i><math>\frac{1}{3}</math> daripada 156 ialah</i>                      A 130                                  C 182                      B 156                                  D 208</p>	<p><b>27</b> <math>\frac{1}{3}</math> of 909 is  <i><math>\frac{1}{3}</math> daripada 909 ialah</i>                      A 1 212                              C 1 818                      B 1 515                              D 2 121</p>

<p><b>28</b> <math>3\frac{2}{3} \times 54 =</math></p> <p>A 162                      C 198 B 180                      D 216</p>	<p><b>28</b> <math>1\frac{1}{3} \times 675 =</math></p> <p>A 562                      C 787 B 675                      D 900</p>
<p><b>29</b> <math>\frac{42}{9} \times 81 =</math></p> <p>A 369                      C 387 B 378                      D 396</p>	<p><b>29</b> <math>\frac{19}{4} \times 652 =</math></p> <p>A 3097                    C 3423 B 3260                    D 3586</p>
<p><b>30</b> <math>3\frac{1}{3} \times 228 =</math></p> <p>A 532                      C 684 B 608                      D 760</p>	<p><b>30</b> <math>7\frac{1}{2} \times 896 =</math></p> <p>A 6 272                    C 6 570 B 6 421                    D 6 720</p>
<p><b>31</b> <math>3\frac{1}{3}</math> of 39 is <i><math>3\frac{1}{3}</math> daripada 39 ialah</i></p> <p>A 91                        C 117 B 104                      D 130</p>	<p><b>31</b> <math>2\frac{3}{4}</math> of 804 is <i><math>2\frac{3}{4}</math> daripada 804 ialah</i></p> <p>A 2 211                    C 2 412 B 2 311                    D 2 512</p>
<p><b>32</b> <math>5\frac{2}{5} \div 2</math></p> <p>A <math>2\frac{7}{10}</math>                    C <math>1\frac{7}{20}</math> B <math>1\frac{4}{5}</math>                     D <math>1\frac{2}{25}</math></p>	<p><b>32</b> <math>4\frac{2}{5} \div 3</math></p> <p>A <math>2\frac{1}{5}</math>                      C <math>1\frac{1}{10}</math> B <math>1\frac{7}{15}</math>                    D <math>\frac{22}{25}</math></p>
<p><b>33</b> Which of the following is the smallest? <i>Antara yang berikut, yang manakah paling kecil?</i></p> <p>A <math>3\frac{1}{3} \div \frac{1}{3}</math>                    C <math>3\frac{5}{7} \div \frac{13}{14}</math> B <math>4\frac{1}{3} \div \frac{1}{3}</math>                    D <math>2\frac{2}{3} \div \frac{2}{3}</math></p>	<p><b>33</b> Which of the following is the smallest? <i>Antara yang berikut, yang manakah paling kecil?</i></p> <p>A <math>5\frac{3}{4} \div \frac{1}{2}</math>                    C <math>5\frac{2}{3} \div \frac{1}{2}</math> B <math>4\frac{1}{7} \div \frac{4}{7}</math>                    D <math>3\frac{1}{3} \div \frac{1}{3}</math></p>
<p><b>34</b> <math>2\frac{2}{3} \div 10</math></p> <p>A <math>\frac{8}{21}</math>                        C <math>\frac{8}{27}</math> B <math>\frac{1}{3}</math>                        D <math>\frac{4}{15}</math></p>	<p><b>34</b> <math>2\frac{4}{5} \div 7</math></p> <p>A <math>\frac{14}{25}</math>                      C <math>\frac{2}{5}</math> B <math>\frac{7}{15}</math>                      D <math>\frac{7}{20}</math></p>
<p><b>35</b> <math>\frac{4}{5} \div 3 =</math></p> <p>A <math>\frac{4}{5}</math>                        C <math>\frac{4}{15}</math> B <math>\frac{2}{5}</math>                        D <math>\frac{1}{5}</math></p>	<p><b>35</b> <math>\frac{2}{5} \div 4 =</math></p> <p>A <math>\frac{2}{15}</math>                        C <math>\frac{2}{25}</math> B <math>\frac{1}{10}</math>                      D <math>\frac{1}{15}</math></p>

<p>36 <math>\frac{1}{4} \div \frac{1}{2} =</math></p> <p>A <math>\frac{1}{2}</math>                      C <math>\frac{1}{6}</math></p> <p>B <math>\frac{1}{4}</math>                        D <math>\frac{1}{8}</math></p>	<p>36 <math>\frac{1}{2} \div \frac{3}{5} =</math></p> <p>A <math>2\frac{1}{2}</math>                      C <math>\frac{5}{6}</math></p> <p>B <math>1\frac{1}{4}</math>                        D <math>\frac{5}{8}</math></p>
<p>37 <math>5\frac{2}{3} \div 3</math></p> <p>A <math>1\frac{8}{9}</math>                      C <math>1\frac{2}{15}</math></p> <p>B <math>1\frac{5}{12}</math>                      D <math>\frac{17}{18}</math></p>	<p>37 <math>4\frac{1}{2} \div 7</math></p> <p>A <math>\frac{9}{10}</math>                        C <math>\frac{9}{14}</math></p> <p>B <math>\frac{3}{4}</math>                         D <math>\frac{9}{16}</math></p>
<p>38 Divide <math>3\frac{4}{5}</math> with <math>\frac{2}{5}</math>.</p> <p><i>Bahagikan <math>3\frac{4}{5}</math> dengan <math>\frac{2}{5}</math>.</i></p> <p>A <math>9\frac{1}{2}</math>                        C <math>4\frac{3}{4}</math></p> <p>B <math>6\frac{1}{3}</math>                        D <math>3\frac{4}{5}</math></p>	<p>38 Divide <math>2\frac{1}{4}</math> with <math>\frac{1}{2}</math>.</p> <p><i>Bahagikan <math>2\frac{1}{4}</math> dengan <math>\frac{1}{2}</math>.</i></p> <p>A 9                            C 3</p> <p>B <math>4\frac{1}{2}</math>                        D <math>2\frac{1}{4}</math></p>
<p>39 <math>4\frac{3}{4} \div \frac{1}{2} =</math></p> <p>A <math>9\frac{1}{2}</math>                        C <math>3\frac{1}{6}</math></p> <p>B <math>4\frac{3}{4}</math>                        D <math>2\frac{3}{8}</math></p>	<p>39 <math>5\frac{6}{7} \div \frac{3}{14} =</math></p> <p>A 82                         C <math>27\frac{1}{3}</math></p> <p>B 41                         D <math>20\frac{1}{2}</math></p>
<p>40 Divide <math>1\frac{2}{5}</math> with <math>\frac{7}{10}</math>.</p> <p><i>Bahagikan <math>1\frac{2}{5}</math> dengan <math>\frac{7}{10}</math>.</i></p> <p>A 2                            C <math>1\frac{5}{9}</math></p> <p>B <math>1\frac{3}{4}</math>                        D <math>1\frac{2}{5}</math></p>	<p>40 Divide <math>2\frac{1}{2}</math> with <math>\frac{1}{4}</math>.</p> <p><i>Bahagikan <math>2\frac{1}{2}</math> dengan <math>\frac{1}{4}</math>.</i></p> <p>A 10                         C <math>3\frac{1}{3}</math></p> <p>B 5                         D <math>2\frac{1}{2}</math></p>

**LATIHAN CUTI SEKOLAH:**

**UNIT 3: PERPULUHAN**

**ASAS 1**

1.  $1.27 \times 7 =$

2.  $1.346 \times 25 =$

3.  $3.6 \div 8 =$

4.  $53.48 \div 14 =$

5. Find the perimeter of the rectangle.

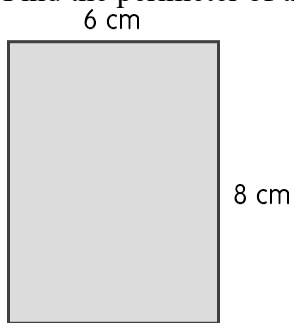

6. Find the perimeter of the rectangle.

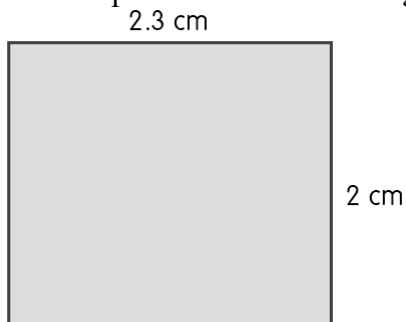

7. Find the perimeter.

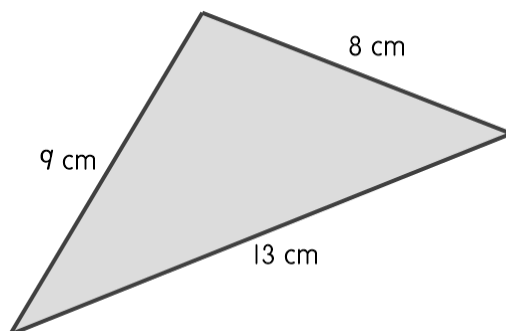

8. Find the perimeter.

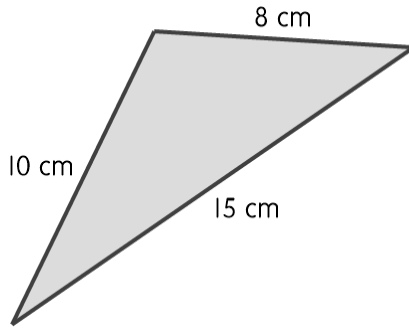

9. Find the area of the rectangle.

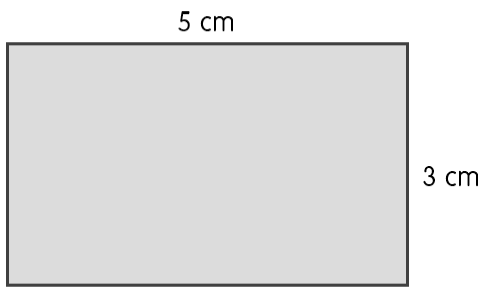

10. Find the area of the rectangle.

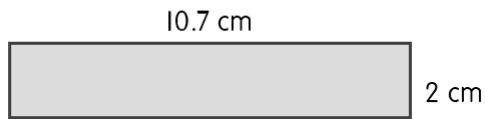

11. Find the area of the triangle.

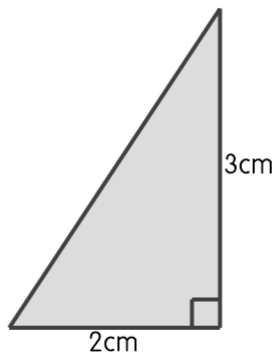

12. Find the area of the triangle.

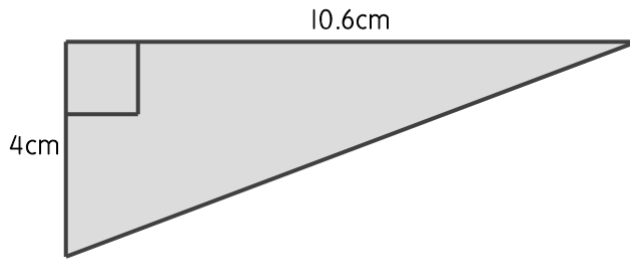

13. The perimeter of the rectangle is 30 cm. Find the value of  $w$ .

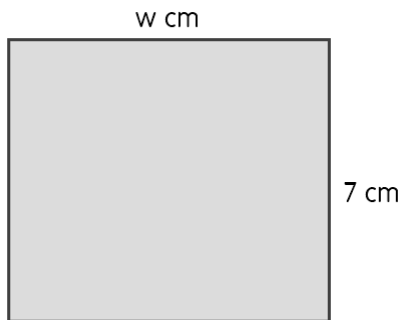

14. The perimeter of the rectangle is 17.8 cm. Find the value of  $w$ .

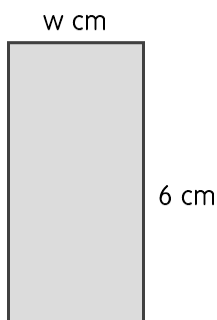

15. A ship departs from a pier and sails 1.4 km to the north on the first day, 0.16 km to the north on the second day and 0.76 km to the south on the third day. What is the distance in km between the ship and the pier after the third day?

16. A ship departs from a pier and sails 76.9 km to the north on the first day, 0.27 km to the south on the second day and 1.36 km to the north on the third day. What is the distance in km between the ship and the pier after the third day?

17. There are 4 decimals. The first decimal is 2.9. The second decimal is 3.7 bigger than the first decimal. The third decimal is 0.88 smaller than the second decimal. The fourth decimal is 0.65 smaller than the third decimal. What is the fourth decimal?

18. There are 4 decimals. The first decimal is 26.8. The second decimal is 36.1 bigger than the first decimal. The third decimal is 0.052 smaller than the second decimal. The fourth decimal is 47.74 bigger than the third decimal. What is the fourth decimal?

**ASAS 2**

INPUT		OUTPUT	
1	$65 \text{ kg } 854 \text{ g} - 36 \text{ kg } 92 \text{ g} + 34 \text{ kg } 386 \text{ g} =$ $\underline{\hspace{2cm}} \text{ kg}$ A 29.762                      C 136.332 B 31.468                      D 64.148	1	$84 \text{ kg } 955 \text{ g} - 2 \text{ kg } 94 \text{ g} + 98 \text{ kg } 816 \text{ g} =$ $\underline{\hspace{2cm}} \text{ kg}$ A 13.861                      C 181.677 B 82.861                      D 185.865
2	A Mathematics book weighs 5.28 kg. A Science book is 2.76 kg lighter than the Mathematics book. What is the total mass, in kg, of the Mathematics and Science books? <i>Sebuah buku Matematik berjisim 5.28 kg. Sebuah buku Sains adalah 2.76 kg lebih ringan daripada buku Matematik. Apakah jumlah jisim bagi kedua-dua buah buku Matematik dan Sains, dalam kg?</i> A 7.8                              C 10.56 B 8.04                            D 13.32	2	A Mathematics book weighs 5.31 kg. A Science book is 4.26 kg lighter than the Mathematics book. What is the total mass, in kg, of the Mathematics and Science books? <i>Sebuah buku Matematik berjisim 5.31 kg. Sebuah buku Sains adalah 4.26 kg lebih ringan daripada buku Matematik. Apakah jumlah jisim bagi kedua-dua buah buku Matematik dan Sains, dalam kg?</i> A 6.36                            C 10.62 B 9.57                            D 14.88
3	$0.588 + 7.754 - 4.06 =$ A 3.472                      C 12.402 B 8.342                      D 4.282	3	$0.682 + 6.636 - 1.94 =$ A 9.258                      C 7.318 B 5.378                      D 1.258
4	$\frac{4906}{1000} =$ A $8.212 + 0.428 - 0.951$ B $8.483 - 6.414 + 7.476$ C $3.999 - 3.222 + 3.343$ D $6.499 - 2.262 + 0.669$	4	$\frac{2262}{1000} =$ A $4.017 + 0.945 - 0.727$ B $7.255 - 1.292 + 2.609$ C $6.508 - 5.154 + 4.484$ D $4.245 - 2.532 + 0.549$

<p><b>5</b> Husain was 1.42 m tall last year. He grew 0.09 m in this year but he was still 0.08 m shorter than his brother, Tabani. What was Tabani's height? <i>Ketinggian Husain pada tahun lepas ialah 1.42 m. Tingginya bertambah 0.09 m dalam tahun ini tetapi dia masih 0.08 m lebih rendah daripada abangnya, Tabani. Apakah ketinggian Tabani?</i></p> <p><b>A</b> 1.49                      <b>C</b> 1.51 <b>B</b> 1.5                         <b>D</b> 1.59</p>	<p><b>5</b> Arsyad was 1.64 m tall last year. He grew 0.04 m in this year but he was still 0.02 m shorter than his brother, Nizar. What was Nizar's height? <i>Ketinggian Arsyad pada tahun lepas ialah 1.64 m. Tingginya bertambah 0.04 m dalam tahun ini tetapi dia masih 0.02 m lebih rendah daripada abangnya, Nizar. Apakah ketinggian Nizar?</i></p> <p><b>A</b> 1.66                      <b>C</b> 1.7 <b>B</b> 1.68                      <b>D</b> 1.67</p>
<p><b>6</b> Mdm Li Hua bought 4.9 kg of apple, 7.567 kg of orange and 6 kg of mango. Calculate the total mass, in kg, of fruit bought by Mdm Li Hua. <i>Mdm Li Hua membeli 4.9 kg epal, 7.567 kg oren dan 6 kg mangga. Hitungkan jumlah jisim buah-buahan yang telah dibeli oleh Mdm Li Hua, dalam kg.</i></p> <p><b>A</b> 10.9                        <b>C</b> 12.467 <b>B</b> 12.367                    <b>D</b> 18.467</p>	<p><b>6</b> Puan Rosnidar bought 2 kg of apple, 1.626 kg of orange and 6 kg of mango. Calculate the total mass, in kg, of fruit bought by Puan Rosnidar. <i>Puan Rosnidar membeli 2 kg epal, 1.626 kg oren dan 6 kg mangga. Hitungkan jumlah jisim buah-buahan yang telah dibeli oleh Puan Rosnidar, dalam kg.</i></p> <p><b>A</b> 3.526                      <b>C</b> 8 <b>B</b> 3.626                      <b>D</b> 9.626</p>
<p><b>7</b> <math>5.55 - (2.03 + 1.18) =</math> <b>A</b> 2.34                      <b>C</b> 4.7 <b>B</b> 2.42                      <b>D</b> 4.78</p>	<p><b>7</b> <math>6.1 - (1.61 + 3.85) =</math> <b>A</b> 0.64                      <b>C</b> 8.34 <b>B</b> 0.72                      <b>D</b> 8.44</p>
<p><b>8</b> <math>51.2 + 11 - 31.9 =</math> <b>A</b> 19.3                      <b>C</b> 62.2 <b>B</b> 30.3                      <b>D</b> 94.1</p>	<p><b>8</b> <math>96.51 + 11 - 11.4 =</math> <b>A</b> 96.11                    <b>C</b> 107.51 <b>B</b> 118.91                   <b>D</b> 85.11</p>
<p><b>9</b> <math>67.71 + 26.27 + 90.93 - 54.5 =</math> <b>A</b> 130.41                  <b>C</b> 184.91 <b>B</b> 62.7                      <b>D</b> 104.14</p>	<p><b>9</b> <math>50.98 + 12.19 + 91.36 - 99.3 =</math> <b>A</b> 4.25                      <b>C</b> 55.23 <b>B</b> 43.04                    <b>D</b> 154.53</p>
<p><b>10</b> <math>88 - \square + 4.03 = 74.6</math> The number in the box is <i>Nombor dalam petak ialah</i></p> <p><b>A</b> 17.43                      <b>C</b> 18.53 <b>B</b> 17.53                      <b>D</b> 18.43</p>	<p><b>10</b> <math>85 - \square + 67.25 = 142.2</math> The number in the box is <i>Nombor dalam petak ialah</i></p> <p><b>A</b> 10.05                    <b>C</b> 11.15 <b>B</b> 11.05                    <b>D</b> 10.15</p>
<p><b>11</b> <math>9.008 + 0.259 - 1.844 =</math> <b>A</b> 7.164                    <b>C</b> 9.267 <b>B</b> 7.423                    <b>D</b> 11.111</p>	<p><b>11</b> <math>9.922 + 0.236 - 3.439 =</math> <b>A</b> 6.719                    <b>C</b> 13.597 <b>B</b> 6.483                    <b>D</b> 10.158</p>
<p><b>12</b> A Mathematics book weighs 9.62 kg. A Science book is 8.01 kg lighter than the Mathematics book. What is the total mass, in kg, of the Mathematics and Science books? <i>Sebuah buku Matematik berjisim 9.62 kg. Sebuah buku Sains adalah 8.01 kg lebih ringan daripada buku Matematik. Apakah jumlah jisim bagi kedua-dua buah buku Matematik dan Sains, dalam kg?</i></p> <p><b>A</b> 11.23                      <b>C</b> 19.24 <b>B</b> 17.63                      <b>D</b> 27.25</p>	<p><b>12</b> A Mathematics book weighs 6.02 kg. A Science book is 2.96 kg lighter than the Mathematics book. What is the total mass, in kg, of the Mathematics and Science books? <i>Sebuah buku Matematik berjisim 6.02 kg. Sebuah buku Sains adalah 2.96 kg lebih ringan daripada buku Matematik. Apakah jumlah jisim bagi kedua-dua buah buku Matematik dan Sains, dalam kg?</i></p> <p><b>A</b> 12.04                      <b>C</b> 8.98 <b>B</b> 9.08                        <b>D</b> 15</p>

<p><b>13</b> The difference of 46.61 and 75.45 is added to <math>x</math> to get 100. What is the value of <math>x</math>? <i>Perbezaan 46.61 dan 75.45 ditambah kepada <math>x</math> untuk mendapatkan 100. Apakah nilai <math>x</math>?</i></p> <p><b>A</b> 24.55                      <b>C</b> 53.39 <b>B</b> 28.84                      <b>D</b> 71.16</p>	<p><b>13</b> The difference of 58.9 and 65.47 is added to <math>x</math> to get 100. What is the value of <math>x</math>? <i>Perbezaan 58.9 dan 65.47 ditambah kepada <math>x</math> untuk mendapatkan 100. Apakah nilai <math>x</math>?</i></p> <p><b>A</b> 34.53                      <b>C</b> 93.43 <b>B</b> 41.1                        <b>D</b> 6.57</p>
<p><b>14</b> <math>9.17 - (6.94 + 1.35) =</math></p> <p><b>A</b> 0.88                      <b>C</b> 3.58 <b>B</b> 0.93                      <b>D</b> 3.61</p>	<p><b>14</b> <math>9.6 - (2.28 + 6.44) =</math></p> <p><b>A</b> 0.88                      <b>C</b> 13.76 <b>B</b> 0.97                      <b>D</b> 13.85</p>
<p><b>15</b> <math>3.24 - (1.05 + 1.16) =</math></p> <p><b>A</b> 1.03                      <b>C</b> 3.38 <b>B</b> 1.09                      <b>D</b> 3.35</p>	<p><b>15</b> <math>9 - (1.13 + 1.52) =</math></p> <p><b>A</b> 9.39                      <b>C</b> 9.48 <b>B</b> 6.45                      <b>D</b> 6.35</p>
<p><b>16</b> The difference of 89.92 and 78.57 is added to <math>x</math> to get 100. What is the value of <math>x</math>? <i>Perbezaan 89.92 dan 78.57 ditambah kepada <math>x</math> untuk mendapatkan 100. Apakah nilai <math>x</math>?</i></p> <p><b>A</b> 11.35                      <b>C</b> 88.65 <b>B</b> 10.08                      <b>D</b> 21.43</p>	<p><b>16</b> The difference of 17.69 and 42.81 is added to <math>x</math> to get 100. What is the value of <math>x</math>? <i>Perbezaan 17.69 dan 42.81 ditambah kepada <math>x</math> untuk mendapatkan 100. Apakah nilai <math>x</math>?</i></p> <p><b>A</b> 25.12                      <b>C</b> 74.88 <b>B</b> 57.19                      <b>D</b> 82.31</p>
<p><b>17</b> <math>0.554 + 6.795 - 5.25 =</math></p> <p><b>A</b> 12.599                    <b>C</b> 2.099 <b>B</b> 4.696                      <b>D</b> 7.349</p>	<p><b>17</b> <math>0.449 + 9.691 - 1.61 =</math></p> <p><b>A</b> 1.161                      <b>C</b> 10.14 <b>B</b> 8.53                        <b>D</b> 11.75</p>
<p><b>18</b> Encik Mohammad took 2 hours to complete a mathematics exercise whereas Mr Ganesh took 0.1 hour less than Encik Mohammad to complete the same exercise. Find the total time, in hours, taken by Encik Mohammad and Mr Ganesh to complete the exercise. <i>Encik Mohammad mengambil masa 2 jam untuk menyelesaikan latihan matematik sementara Mr Ganesh mengambil masa 0.1 jam kurang daripada Encik Mohammad untuk menyelesaikan latihan yang sama. Cari jumlah masa yang diambil oleh Encik Mohammad dan Mr Ganesh untuk menyelesaikan latihan tersebut, dalam jam.</i></p> <p><b>A</b> 2.1                        <b>C</b> 4 <b>B</b> 3.9                        <b>D</b> 4.1</p>	<p><b>18</b> Encik Omar took 3 hours to complete a mathematics exercise whereas Mr Raju took 0.4 hour less than Encik Omar to complete the same exercise. Find the total time, in hours, taken by Encik Omar and Mr Raju to complete the exercise. <i>Encik Omar mengambil masa 3 jam untuk menyelesaikan latihan matematik sementara Mr Raju mengambil masa 0.4 jam kurang daripada Encik Omar untuk menyelesaikan latihan yang sama. Cari jumlah masa yang diambil oleh Encik Omar dan Mr Raju untuk menyelesaikan latihan tersebut, dalam jam.</i></p> <p><b>A</b> 3.4                        <b>C</b> 5.6 <b>B</b> 6.4                        <b>D</b> 6</p>
<p><b>19</b> Ramli has a brown ribbon and a blue ribbon. The brown ribbon is 9.27 m long and the blue ribbon is 2.7 m shorter than the brown ribbon. Find the total length, in m, of the two ribbons. <i>Ramli mempunyai reben perang dan reben biru. Reben perang ialah 9.27 m panjang dan reben biru adalah 2.7 m lebih pendek daripada reben perang. Cari jumlah panjang bagi kedua-dua reben, dalam m.</i></p> <p><b>A</b> 11.97                      <b>C</b> 18.54 <b>B</b> 15.84                      <b>D</b> 21.24</p>	<p><b>19</b> Asmar has a red ribbon and a white ribbon. The red ribbon is 5.7 m long and the white ribbon is 3.2 m shorter than the red ribbon. Find the total length, in m, of the two ribbons. <i>Asmar mempunyai reben merah dan reben putih. Reben merah ialah 5.7 m panjang dan reben putih adalah 3.2 m lebih pendek daripada reben merah. Cari jumlah panjang bagi kedua-dua reben, dalam m.</i></p> <p><b>A</b> 8.2                        <b>C</b> 11.4 <b>B</b> 8.9                        <b>D</b> 14.6</p>

<p><b>20</b> A Mathematics book weighs 7.83 kg. A Science book is 7.34 kg lighter than the Mathematics book. What is the total mass, in kg, of the Mathematics and Science books? <i>Sebuah buku Matematik berjisim 7.83 kg. Sebuah buku Sains adalah 7.34 kg lebih ringan daripada buku Matematik. Apakah jumlah jisim bagi kedua-dua buah buku Matematik dan Sains, dalam kg?</i></p> <p><b>A</b> 8.32                      <b>C</b> 15.66 <b>B</b> 15.17                      <b>D</b> 23</p>	<p><b>20</b> A Mathematics book weighs 9.51 kg. A Science book is 8.46 kg lighter than the Mathematics book. What is the total mass, in kg, of the Mathematics and Science books? <i>Sebuah buku Matematik berjisim 9.51 kg. Sebuah buku Sains adalah 8.46 kg lebih ringan daripada buku Matematik. Apakah jumlah jisim bagi kedua-dua buah buku Matematik dan Sains, dalam kg?</i></p> <p><b>A</b> 10.56                      <b>C</b> 19.02 <b>B</b> 17.97                      <b>D</b> 27.48</p>
<p><b>21</b> A purple ball weighs 2.72 g. A green ball is 7.96 g heavier than a purple ball. What is the total mass, in g, of both ball? <i>Sebiji bola ungu berjisim 2.72 g. Sebiji bola hijau adalah 7.96 g lebih berat daripada bola ungu. Apakah jumlah jisim bagi kedua-dua biji bola, dalam g?</i></p> <p><b>A</b> 5.24                      <b>C</b> 13.4 <b>B</b> 7.96                      <b>D</b> 10.68</p>	<p><b>21</b> A blue ball weighs 1.28 g. A white ball is 8.69 g heavier than a blue ball. What is the total mass, in g, of both ball? <i>Sebiji bola biru berjisim 1.28 g. Sebiji bola putih adalah 8.69 g lebih berat daripada bola biru. Apakah jumlah jisim bagi kedua-dua biji bola, dalam g?</i></p> <p><b>A</b> 7.41                      <b>C</b> 9.97 <b>B</b> 8.69                      <b>D</b> 11.25</p>
<p><b>22</b> Syukur travels 16.92 km by car. Ikhwan travels 9.3 km less than Syukur. Find the total distance, in km, travelled by both of them. <i>Syukur bergerak sejauh 16.92 km dengan kereta. Ikhwan bergerak sejauh 9.3 km kurang daripada Syukur. Cari jumlah jarak yang dilalui oleh mereka, dalam km.</i></p> <p><b>A</b> 24.54                      <b>C</b> 33.84 <b>B</b> 26.22                      <b>D</b> 43.14</p>	<p><b>22</b> Han Leong travels 89.72 km by car. Yong Seng travels 5.4 km less than Han Leong. Find the total distance, in km, travelled by both of them. <i>Han Leong bergerak sejauh 89.72 km dengan kereta. Yong Seng bergerak sejauh 5.4 km kurang daripada Han Leong. Cari jumlah jarak yang dilalui oleh mereka, dalam km.</i></p> <p><b>A</b> 95.12                      <b>C</b> 179.44 <b>B</b> 174.04                      <b>D</b> 184.84</p>
<p><b>23</b> <math>7.2 + 0.88 + \square = 9.88</math> The number in the box is <i>Nombor dalam petak ialah</i></p> <p><b>A</b> 6.32                      <b>C</b> 2.68 <b>B</b> 1.8                      <b>D</b> 9</p>	<p><b>23</b> <math>7.17 + 0.49 + \square = 16.7</math> The number in the box is <i>Nombor dalam petak ialah</i></p> <p><b>A</b> 9.53                      <b>C</b> 9.04 <b>B</b> 6.68                      <b>D</b> 16.21</p>
<p><b>24</b> Subtract 50.8 from the sum of 61.546 and 3.36. <i>Tolak 50.8 daripada jumlah 61.546 dan 3.36.</i></p> <p><b>A</b> 10.746                      <b>C</b> 64.906 <b>B</b> 14.106                      <b>D</b> 115.706</p>	<p><b>24</b> Subtract 22.1 from the sum of 38.356 and 1.41. <i>Tolak 22.1 daripada jumlah 38.356 dan 1.41.</i></p> <p><b>A</b> 16.256                      <b>C</b> 39.766 <b>B</b> 17.666                      <b>D</b> 61.866</p>
<p><b>25</b> <math>3.7 = 3 + \frac{p}{250} + \frac{96}{1000}</math> The value of <math>p</math> is <i>Nilai <math>p</math> ialah</i></p> <p><b>A</b> 151                      <b>C</b> 155 <b>B</b> 152                      <b>D</b> 156</p>	<p><b>25</b> <math>2.673 = 2 + \frac{p}{8} + \frac{48}{1000}</math> The value of <math>p</math> is <i>Nilai <math>p</math> ialah</i></p> <p><b>A</b> 5                      <b>C</b> 8 <b>B</b> 6                      <b>D</b> 10</p>

<p><b>26</b> Puan Lily had 35 ℓ of water left after using 8.1 ℓ to make orange juice and 5.04 ℓ to make apple juice. What was the original volume, in ℓ, of water? <i>Puan Lily masih mempunyai 35 ℓ air tertinggal setelah menggunakan 8.1 ℓ air untuk membuat jus oren dan 5.04 ℓ air untuk membuat jus epal. Apakah isi padu asal air, dalam ℓ?</i></p> <p>A 13.14                      C 43.14 B 40.04                      D 48.14</p>	<p><b>26</b> Mdm Li Hua had 19 ℓ of water left after using 1.1 ℓ to make orange juice and 4.13 ℓ to make apple juice. What was the original volume, in ℓ, of water? <i>Mdm Li Hua masih mempunyai 19 ℓ air tertinggal setelah menggunakan 1.1 ℓ air untuk membuat jus oren dan 4.13 ℓ air untuk membuat jus epal. Apakah isi padu asal air, dalam ℓ?</i></p> <p>A 23.13                      C 24.23 B 5.23                        D 20.13</p>																												
<p><b>27</b> <math>6.75 + 6.1 - 3.56 + 0.2 =</math> A 3.76                        C 9.49 B 12.85                      D 2.54</p>	<p><b>27</b> <math>7.31 + 9.7 - 3.48 + 0.45 =</math> A 6.22                        C 13.98 B 17.01                      D 3.93</p>																												
<p><b>28</b> Weng Hung has a blue ribbon and a red ribbon. The blue ribbon is 7.8 m long and the red ribbon is 0.3 m shorter than the blue ribbon. Find the total length, in m, of the two ribbons. <i>Weng Hung mempunyai reben biru dan reben merah. Reben biru ialah 7.8 m panjang dan reben merah adalah 0.3 m lebih pendek daripada reben biru. Cari jumlah panjang bagi kedua-dua reben, dalam m.</i></p> <p>A 8.1                          C 15.6 B 15.3                        D 15.9</p>	<p><b>28</b> Hooi Leng has a red ribbon and a yellow ribbon. The red ribbon is 7.43 m long and the yellow ribbon is 7.35 m shorter than the red ribbon. Find the total length, in m, of the two ribbons. <i>Hooi Leng mempunyai reben merah dan reben kuning. Reben merah ialah 7.43 m panjang dan reben kuning adalah 7.35 m lebih pendek daripada reben merah. Cari jumlah panjang bagi kedua-dua reben, dalam m.</i></p> <p>A 7.51                        C 14.86 B 14.78                      D 22.21</p>																												
<p><b>29</b> <math>980.1 - 44.9 - 2.83 + 4.07 =</math> A 942.1                      C 1 023.76 B 936.44                    D 1 018.1</p>	<p><b>29</b> <math>638.5 - 35.1 - 6.36 + 2.48 =</math> A 612.24                    C 599.52 B 677.48                    D 664.76</p>																												
<p><b>30</b> <math>8.257 - 7.454 + 5.86 =</math> A 0.803                      C 14.117 B 6.663                      D 21.571</p>	<p><b>30</b> <math>3.427 - 1.412 + 4.3 =</math> A 2.015                      C 7.727 B 6.315                      D 9.139</p>																												
<p><b>31</b> Diagram 1 shows a number card. <i>Rajah 1 menunjukkan satu kad nombor.</i></p> <table border="1" style="margin-left: auto; margin-right: auto;"> <tr> <td style="padding: 2px 5px;">1</td> <td style="padding: 2px 5px;">3</td> <td style="padding: 2px 5px;">7</td> <td style="padding: 2px 5px;">.</td> <td style="padding: 2px 5px;">9</td> <td style="padding: 2px 5px;">9</td> <td style="padding: 2px 5px;">7</td> </tr> <tr> <td style="text-align: center; padding: 2px 5px;">P</td> <td style="text-align: center; padding: 2px 5px;">Q</td> <td style="text-align: center; padding: 2px 5px;">R</td> <td></td> <td style="text-align: center; padding: 2px 5px;">S</td> <td style="text-align: center; padding: 2px 5px;">T</td> <td style="text-align: center; padding: 2px 5px;">U</td> </tr> </table> <p style="text-align: center;"><b>Diagram 1</b> <b>Rajah 1</b></p> <p>Find the value of digit values of <math>P - R + U</math>. <i>Cari nilai bagi nilai digit <math>P - R + U</math>.</i></p> <p>A 70.007                      C 70.9 B 70.09                        D 93.007</p>	1	3	7	.	9	9	7	P	Q	R		S	T	U	<p><b>31</b> Diagram 1 shows a number card. <i>Rajah 1 menunjukkan satu kad nombor.</i></p> <table border="1" style="margin-left: auto; margin-right: auto;"> <tr> <td style="padding: 2px 5px;">1</td> <td style="padding: 2px 5px;">4</td> <td style="padding: 2px 5px;">9</td> <td style="padding: 2px 5px;">.</td> <td style="padding: 2px 5px;">3</td> <td style="padding: 2px 5px;">8</td> <td style="padding: 2px 5px;">3</td> </tr> <tr> <td style="text-align: center; padding: 2px 5px;">P</td> <td style="text-align: center; padding: 2px 5px;">Q</td> <td style="text-align: center; padding: 2px 5px;">R</td> <td></td> <td style="text-align: center; padding: 2px 5px;">S</td> <td style="text-align: center; padding: 2px 5px;">T</td> <td style="text-align: center; padding: 2px 5px;">U</td> </tr> </table> <p style="text-align: center;"><b>Diagram 1</b> <b>Rajah 1</b></p> <p>Find the value of digit values of <math>P - R + T</math>. <i>Cari nilai bagi nilai digit <math>P - R + T</math>.</i></p> <p>A 60.08                        C 91.003 B 60.3                         D 91.08</p>	1	4	9	.	3	8	3	P	Q	R		S	T	U
1	3	7	.	9	9	7																							
P	Q	R		S	T	U																							
1	4	9	.	3	8	3																							
P	Q	R		S	T	U																							

**32** Diagram 2 shows the mass of a kettle.  
*Rajah 2 menunjukkan jisim sebuah cerek.*



1.2 kg

**Diagram 2**  
**Rajah 2**

An oven is 1 kg heavier than the kettle and a rice cooker is 0.456 kg lighter than the oven. What is the total mass, in kg, of kettle, oven and rice cooker?

*Sebuah ketuhar adalah 1 kg berat daripada cerek dan sebuah periuk nasi adalah 0.456 kg ringan daripada ketuhar. Apakah jumlah jisim bagi ketiga-tiga buah cerek, ketuhar dan periuk nasi, dalam kg?*

- A 2.944                      C 3.944  
B 3.4                          D 5.144

**32** Diagram 2 shows the mass of a kettle.  
*Rajah 2 menunjukkan jisim sebuah cerek.*



1.9 kg

**Diagram 2**  
**Rajah 2**

An oven is 1.2 kg heavier than the kettle and a rice cooker is 0.91 kg lighter than the oven. What is the total mass, in kg, of kettle, oven and rice cooker?

*Sebuah ketuhar adalah 1.2 kg berat daripada cerek dan sebuah periuk nasi adalah 0.91 kg ringan daripada ketuhar. Apakah jumlah jisim bagi ketiga-tiga buah cerek, ketuhar dan periuk nasi, dalam kg?*

- A 7.19                        C 5  
B 5.29                        D 4.09

**33**  $90 \text{ kg } 637 \text{ g} - 7 \text{ kg } 134 \text{ g} + 86 \text{ kg } 281 \text{ g} =$   
\_\_\_\_\_ kg

- A 169.784                      C 83.503  
B 4.356                        D 184.052

**33**  $75 \text{ kg } 418 \text{ g} - 65 \text{ kg } 16 \text{ g} + 93 \text{ kg } 257 \text{ g} =$   
\_\_\_\_\_ kg

- A 233.691                      C 10.402  
B 17.839                        D 103.659

**34** Adi has two bottles which contains 6.99 l and 5.13 l of water. He pours 3.89 l of water from each of the two bottles into a container. What is the total volume of water, in l, left in the two bottles?

*Adi mempunyai dua botol yang mengandungi 6.99 l dan 5.13 l air. Dia menuang 3.89 l air daripada setiap botol itu ke dalam sebuah bekas. Berapakah jumlah isipadu air yang tertinggal dalam kedua-dua botol, dalam l?*

- A 4.34                        C 12.12  
B 8.23                        D 13.36

**34** Lutfi has two bottles which contains 4.56 l and 7.3 l of water. He pours 2.35 l of water from each of the two bottles into a container. What is the total volume of water, in l, left in the two bottles?

*Lutfi mempunyai dua botol yang mengandungi 4.56 l dan 7.3 l air. Dia menuang 2.35 l air daripada setiap botol itu ke dalam sebuah bekas. Berapakah jumlah isipadu air yang tertinggal dalam kedua-dua botol, dalam l?*

- A 7.16                        C 9.51  
B 16.81                        D 11.86

**35**  $7.33 + 6.7 = 83.3 - \square$

The number in the box is  
*Nombor dalam petak ialah*

- A 75.97                        C 14.03  
B 69.37                        D 69.27

**35**  $1.91 + 8.93 = 69.6 - \square$

The number in the box is  
*Nombor dalam petak ialah*

- A 10.84                        C 58.86  
B 58.76                        D 67.69

**36** A durian weighs 7 kg. A watermelon is 0.2 kg heavier than durian. What is the total mass, in kg, of the durian and watermelon?

*Sebiji durian berjisim 7 kg. Sebiji tembikai adalah 0.2 kg lebih berat daripada durian. Apakah jumlah jisim bagi kedua-dua biji durian dan tembikai, dalam kg?*

- A 14.2                        C 14  
B 7.2                         D 13.8

**36** A durian weighs 5.8 kg. A watermelon is 0.2 kg heavier than durian. What is the total mass, in kg, of the durian and watermelon?

*Sebiji durian berjisim 5.8 kg. Sebiji tembikai adalah 0.2 kg lebih berat daripada durian. Apakah jumlah jisim bagi kedua-dua biji durian dan tembikai, dalam kg?*

- A 11.8                        C 6  
B 11.6                        D 11.4

<p><b>37</b> Which of the following is wrong? <i>Antara berikutnya, yang manakah adalah salah?</i></p> <p>A <math>9.504 + 0.43 - 0.705 = 9.229</math>                      B <math>5.608 - 4.883 + 2.876 = 3.601</math>                      C <math>7.836 - 3.76 + 4.7 = 8.776</math>                      D <math>7.005 - 5.36 + 0.955 = 3.6</math></p>	<p><b>37</b> Which of the following is correct? <i>Antara berikutnya, yang manakah adalah betul?</i></p> <p>A <math>1.857 + 0.632 - 0.732 = 1.757</math>                      B <math>7.738 - 7.334 + 5.284 = 6.688</math>                      C <math>6.093 - 1.081 + 1.044 = 7.056</math>                      D <math>8.376 - 4.325 + 0.179 = 5.23</math></p>
<p><b>38</b> Zaimah has a white ribbon and a purple ribbon. The white ribbon is 7.99 m long and the purple ribbon is 1.66 m shorter than the white ribbon. Find the total length, in m, of the two ribbons. <i>Zaimah mempunyai reben putih dan reben ungu. Reben putih ialah 7.99 m panjang dan reben ungu adalah 1.66 m lebih pendek daripada reben putih. Cari jumlah panjang bagi kedua-dua reben, dalam m.</i></p> <p>A 15.98                      C 17.64                      B 14.32                      D 9.65</p>	<p><b>38</b> Hilmi has a blue ribbon and a black ribbon. The blue ribbon is 6.77 m long and the black ribbon is 3.61 m shorter than the blue ribbon. Find the total length, in m, of the two ribbons. <i>Hilmi mempunyai reben biru dan reben hitam. Reben biru ialah 6.77 m panjang dan reben hitam adalah 3.61 m lebih pendek daripada reben biru. Cari jumlah panjang bagi kedua-dua reben, dalam m.</i></p> <p>A 10.38                      C 9.93                      B 17.15                      D 13.54</p>
<p><b>39</b> <math>8 - 3.421 + 8.39 =</math></p> <p>A 4.579                      C 19.811                      B 16.39                      D 12.969</p>	<p><b>39</b> <math>8 - 6.535 + 1.47 =</math></p> <p>A 16.005                      C 9.47                      B 2.935                      D 1.465</p>
<p><b>40</b> Encik Lukman has 5 m of wire. He used 3.2 m of it and bought another 15.39 m. What is the length, in m, of wire that Encik Lukman has now? <i>Encik Lukman mempunyai 5 m dawai. Dia menggunakan 3.2 m daripadanya dan membeli 15.39 m dawai lagi selepas itu. Apakah panjang dawai yang Encik Lukman ada sekarang, dalam m?</i></p> <p>A 17.19                      C 18.59                      B 18.19                      D 23.59</p>	<p><b>40</b> Mr Seng has 7 m of wire. He used 6.6 m of it and bought another 19.97 m. What is the length, in m, of wire that Mr Seng has now? <i>Mr Seng mempunyai 7 m dawai. Dia menggunakan 6.6 m daripadanya dan membeli 19.97 m dawai lagi selepas itu. Apakah panjang dawai yang Mr Seng ada sekarang, dalam m?</i></p> <p>A 26.57                      C 20.37                      B 33.57                      D 21.37</p>

# JAWAPAN

## BAB 1: NOMBOR & OPERASI

### ASAS 1

1. 9 011
2. 304 379
3. 50 250
4. 12 866
5. 360
6. 100 128
7. 8 200
8. 600
9. 15 000
10. 13 357
11. 3 486 840
12. 8 432 190
13. 10 000 000
14. 8 000 000
15. 891 840, 891 800, 892 000, 890 000, 900 000, 1 000 000
16. 2 067 420, 2 067 400, 2 067 000, 2 070 000, 2 100 000, 2 000 000
17. 8 764 321
18. 1 245 678
19. 9 005
20. 30 005
21. 4 600 000
22. 299 000
23. 4 605 931
24. 9 813 764
25. 6 149 420
26. 7 065 257
27. 9.33
28. 3.1
29. 11336.33

30. 7044.798
31. 

322	324	326	328	330	332
-----	-----	-----	-----	-----	-----
32. 

400	405	410	415	420	425
-----	-----	-----	-----	-----	-----
33. 

5	11	18	26	35	45
---	----	----	----	----	----
34. 

764	766	769	773	778	784
-----	-----	-----	-----	-----	-----
35. 

2	4	8	16	32	64
---	---	---	----	----	----
36. 

4	16	64	256	1 024	4 096
---	----	----	-----	-------	-------
37. a1
38. a1
39. 2
40. 17, 3, 5
41. 23
42. 41
43. 8 000 000
44. 9 560 057
45. eight million
46. eight million two hundred thirty thousand seventy
47. Tens
48. Hundreds
49. 9 6 1 2 4 8 7
50. 3 9 3 7 9 8 7
51. 1 000
52. 2 000 000
53. 3 000 000 + 900 000 + 10 000 + 2 000 + 200 + 40 + 6
54. 6 000 000 + 500 000 + 30 000 + 9 000 + 400 + 20 + 3
55. 3, 9, 3, 7, 3, 3
56. 8, 1, 5, 0, 3, 4
57. 1 600 000
58. 2 880 000

- 59. 3.7
- 60. 5.25
- 61.  $2\frac{3}{10}$
- 62.  $8\frac{72}{100}$
- 63. 8 700 000
- 64. 9 500 000
- 65. 3.5
- 66. 6.455
- 67. 2 387 000
- 68. 932 000
- 69. 3 577
- 70. 9 235
- 71. 1 900
- 72. 4 986
- 73. 1 370
- 74. 1 756
- 75. 80
- 76. 4 309
- 77. 8 965 000
- 78. 220 000

**ASAS 2 KIRI**

- 1 A 2 D 3 D 4 A 5 B
- 6 D 7 A 8 A 9 D 10 C
- 11 C 12 A 13 A 14 D 15 B
- 16 A 17 C 18 C 19 A 20 B
- 21 A 22 A 23 C 24 B 25 B
- 26 C 27 D 28 C 29 C 30 C
- 31 C 32 C 33 D 34 A 35 A
- 36 D 37 B 38 A 39 A 40 A

**ASAS 2 KANAN**

- 1 B 2 D 3 C 4 D 5 C
- 6 C 7 B 8 D 9 D 10 C
- 11 C 12 A 13 B 14 C 15 C
- 16 D 17 A 18 B 19 B 20 C
- 21 D 22 C 23 A 24 D 25 A
- 26 A 27 C 28 C 29 D 30 C
- 31 C 32 C 33 A 34 A 35 C
- 36 A 37 A 38 A 39 C 40 A

**JAWAPAN**

**BAB 2: PECAHAN**

**ASAS 1**

- 1.  $\frac{16}{63}$
- 2. 10
- 3.  $\frac{1}{6}$
- 4.  $18\frac{3}{4}$
- 5.  $\frac{2}{15}$
- 6.  $12\frac{4}{7}$
- 7. a1
- 8.  $4\frac{1}{2}$
- 9.  $\frac{1}{7}$
- 10.  $\frac{3}{28}$
- 11.  $\frac{7}{8}$
- 12.  $1\frac{13}{28}$
- 13.  $\frac{1}{2}$
- 14.  $\frac{9}{25}$
- 15.  $12\frac{2}{7}$
- 16.  $44\frac{1}{4}$
- 17. a1
- 18. a1
- 19. 72
- 20. 5 037
- 21. 1 600
- 22. 26 425

**ASAS 2 KIRI**

- 1 C 2 A 3 A 4 C 5 D
- 6 C 7 C 8 A 9 B 10 B
- 11 C 12 B 13 B 14 B 15 A
- 16 B 17 A 18 A 19 C 20 C
- 21 B 22 B 23 B 24 A 25 C
- 26 A 27 D 28 C 29 B 30 D
- 31 D 32 A 33 C 34 D 35 C
- 36 A 37 A 38 A 39 A 40 A

**ASAS 2 KANAN**

- 1 C 2 A 3 D 4 A 5 C
- 6 D 7 D 8 A 9 C 10 D
- 11 C 12 B 13 C 14 A 15 C
- 16 B 17 B 18 C 19 B 20 C
- 21 B 22 C 23 B 24 D 25 A
- 26 D 27 A 28 D 29 A 30 D
- 31 A 32 B 33 B 34 C 35 B
- 36 C 37 C 38 B 39 C 40 A

**JAWAPAN**

**BAB 3: PERPULUHAN**

**ASAS 1**

- 1. 8.89
- 2. 33.65
- 3. 0.45
- 4. 3.82
- 5. 28 cm
- 6. 8.6 cm
- 7. 30 cm
- 8. 33 cm
- 9. 15 cm<sup>2</sup>
- 10. 21.4 cm<sup>2</sup>
- 11. 3 cm<sup>2</sup>
- 12. 21.2 cm<sup>2</sup>
- 13. 8 cm

- 14. 2.9 cm
- 15. 0.8
- 16. 77.99
- 17. 5.07
- 18. 110.588

**ASAS 2 KIRI**

- 1 D 2 A 3 D 4 D 5 D
- 6 D 7 A 8 B 9 A 10 A
- 11 B 12 A 13 D 14 A 15 A
- 16 C 17 C 18 B 19 B 20 A
- 21 C 22 A 23 B 24 B 25 A
- 26 D 27 C 28 B 29 B 30 B
- 31 D 32 D 33 A 34 A 35 D
- 36 A 37 D 38 B 39 D 40 A

**ASAS 2 KANAN**

- 1 C 2 A 3 B 4 D 5 C
- 6 D 7 A 8 A 9 C 10 A
- 11 A 12 B 13 C 14 A 15 D
- 16 C 17 B 18 C 19 A 20 A
- 21 D 22 B 23 C 24 B 25 A
- 26 C 27 C 28 A 29 C 30 B
- 31 D 32 A 33 D 34 A 35 B
- 36 A 37 A 38 C 39 B 40 C

# Anak Masih Lemah, Tak Minat & Tak Fokus Dalam Matematik?

## Biar Maths Catch Bantu



**Klik sini**

**[www.mathscatch.com](http://www.mathscatch.com)**